

# AX60+

## Multi-gas CO<sub>2</sub> & O<sub>2</sub> Safety Monitor

Multi-gas monitor for use across many industries



The Ax60+ is a wall-mountable gas safety device for monitoring oxygen and carbon dioxide. Based on the popular Ax60 CO<sub>2</sub> detector, the new Ax60+ offers the additional functionality of a modular O<sub>2</sub> sensor which provides an early warning of both oxygen depletion and oxygen enrichment. The CO<sub>2</sub> and O<sub>2</sub> sensors are interchangeable and can be fully integrated as part of a multi-point, multi-gas detection and alarm system.

The CO<sub>2</sub> sensor is set by default to trigger a low-level alarm at 1.5% CO<sub>2</sub>, an evacuation alarm at 3% CO<sub>2</sub> and a time-weighted average alarm of 0.5% CO<sub>2</sub> measured over eight hours. The O<sub>2</sub> sensor is set by default to trigger low-going alarms at both 19.5% and at 18% and a high-going alarm at 23%. The alarm setpoints can be changed by the user. Warnings are announced by high-visibility strobe lights and high-volume sounders.

### KEY FEATURES

- Multi-point, multi-gas, distributed monitoring system
- 4-channel flexibility allowing any sensor combination
- Central display unit for remote operation and control
- User-configurable alarms, set-points and relay outputs
- Built-in software for operation and maintenance tasks

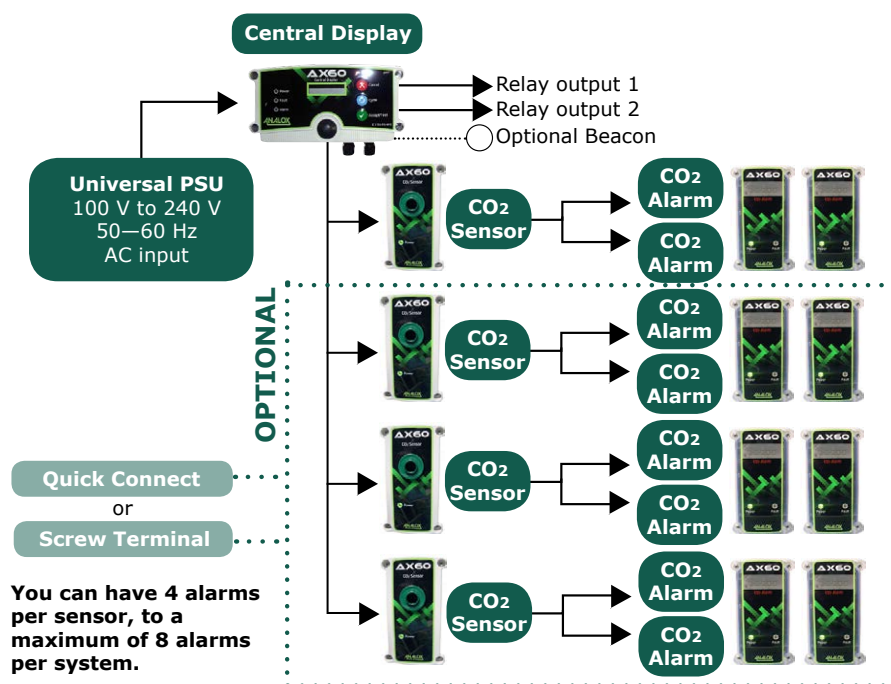

## AX60+

**SPECIFICATIONS** Specifications subject to change without notice

Warm-up time	40 seconds
Operating temperature range	-5 °C to +50 °C, +23 °F to +122 °F
Approvals:	CE, EN50270, IEC 61010 (UL), DIN 6653 (TUV)
<b>CENTRAL DISPLAY</b>	
Display	LCD dot matrix (backlit)
Relays	2 off, default normally open. Rating 1 A/30 V AC/DC
IP Rating	IP54
<b>CO<sub>2</sub> ALARM</b>	
Strobe	White LED strobe > 100 cd (optional blue, red and amber filter)
Sounder	Min 80 dBA @3 m (9.8 feet)
IP Rating	IP55
<b>CO<sub>2</sub> Sensor</b>	
Gas detected	Carbon dioxide
Measurement technique	infrared
Range	0.1% to 5%
Default alarm setpoints	0.5% (8 hour TWA), 1.5%, 3.0%
IP Rating	IP55
Warranty	5 years
<b>O<sub>2</sub> Sensor</b>	
Gas detected	Oxygen
Measurement technique	electrochemical cell (rated for 3-year operation)
Range	0.1% to 25%
Default alarm setpoints	18.0% (low going), 19.5% (low going), 23.0% (high going)
IP Rating	IP55
Warranty	5 years



**t** +61 8 6108 0000

**e** [info@gastech.com](mailto:info@gastech.com)

**w** [gastech.com](http://gastech.com)

**HEAD OFFICE**  
24 Baretta Road  
Wangara WA 6065  
Phone: +61 8 6108 0000

**SYDNEY OFFICE**  
21/25 Narabang Way  
Belrose NSW 2085  
Phone: +61 2 9451 0054

**BRISBANE OFFICE**  
PO Box 349  
Cannon Hill Qld 4170  
Phone: +61 7 3160 0901