

D-Guard™

Digital gas detector



GasTech Australia's latest series of gas detectors: The Digital Guard (D-Guard™). This new style of gas detector uses an advanced processor and program logic, making the choice of a reliable detector simple.

Our engineers have developed high end electronics and a program that monitors the sensor's outputs and is tailored to and pre-programmed to many different gas types. The program and electronics process the sensor's output trends and calculates accurate and stable readings which are displayed on the permanently backlit graphic display. This is transmitted back to the processor using the industry standard 4-20mA.

Mechanical design:

One card to suit all applications is the philosophy. Many of our customers are in remote locations around the world and holding stock for all the different kinds of detectors and ranges that they have on site is expensive and difficult to manage. In the D-Guard™ design this card had to be easily configured for the different gasses, ranges, sensors styles and must have enough program memory to hold the logic for each type of gas. Our engineers were able to achieve all this, with enough resources still available to implement many future features. Each card will be simple to upgrade as needs change.

Housing is a IP 66 carbon impregnated anti static Nylon, which is UV stable. The design of the housing was designed to meet the most challenging conditions encountered in off shore oil rigs.

End user features:

No tool calibration or set up. No screwdrivers, No meters, no special programming tools required to calibrate.

Backlit display. This feature is not available on most loop-powered devices due to high power consumption but it is one of the most requested features, due to operations at night or in dark areas. Our engineers used the latest low power components leaving sufficient resources to implement a back light.

No alarms during calibration. This is probably one of the most useful features of this system. Once you open the calibration door the D-Guard™ locks the output signal at zero gas reading until the calibration process is finished. Our engineers have implemented a fail-safe logic to maintain constant monitoring. There is also an Isolate switch, which will permanently isolate all signals and alarms until the operator reactivates the unit.

Zero stability logic

One man calibration

Non intrusive calibration

Graphical backlit display

No alarm calibration

Simple user options

One board does all

No tool calibration

Isolate feature

Intrinsically safe

Fully programmable processor control

High impact non-static housing

Water resistant IP 66 design

Two year warranty()**

D-Guard™

Sensor & 4-20mA Transmitter Specifications

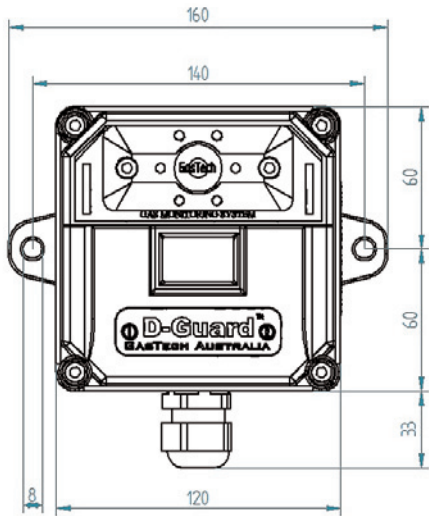

Typical range of Gases Detected

Ammonia (NH ₃)	0 to 100 ppm	in 1 ppm increments
Carbon Monoxide (CO)	0 to 100 ppm	in 1 ppm increments
Chlorine (CL ₂)	0 to 10 ppm	in 0.1 ppm increments
Hydrogen (H ₂)	0 to 100 ppm	in 0.5 ppm increments
Hydrogen Cyanide (HCN)	0 to 50 ppm	in 1 ppm increments
Hydrogen Sulfide (H ₂ S)	0 to 200 ppm	in 1 ppm increments
Hydrogen Chloride (HCL)	0 to 200 ppm	in 1 ppm increments
Nitric Oxide (NO)	0 to 100 ppm	in 1 ppm increments
Nitrogen Dioxide (NO ₂)	0 to 10 ppm	in 0.1 ppm increments
Phosphine (PH ₃)	0 to 1 ppm	in 0.01 ppm increments
Sulfur Dioxide (SO ₂)	0 to 10 ppm	in 0.1 ppm increments
Ethylene Oxide (ETO)	0 to 20 ppm	in 0.1 ppm increments
Ozone (O ₃)	0 to 2 ppm	in 0.01 ppm increments
Oxygen (O ₂)	0 to 25%	in 0.1 %Vol increments
Fluorine (F ₂)	0 to 1ppm	in 0.01 ppm increments

*Increased sensors and detection range available on request.

Analogue Output

Indication

Relay Outputs

Input Power

Response Time

Operating Temperature

Humidity Range

Accuracy

Repeatability

Sensor style

Calibration

Drift

Weight

Dimensions

Enclosure

Certification

IP rating

Warranty

Part Number

Relay version

Two wire 4-20mA

Graphical Back Light LCD display

3 user adjustable SPDT (option)

10-30VDC

90% full scale response in less than 40 seconds sensor dependent

-20°C to +60°C (+55° IS Version) *50°C sensor special

0-95% non condensing

±5% of reading

±1% of reading

Standard 7 series or 4 series plug in sensors

Non intrusive push buttons, no screwdrivers or meters needed

Less than 5% signal loss per year

450g

115mm x 90mm x 55mm

IP66 anti static RFI/EMI UV stable Chemical resistant Nylon

Intrinsically safe IECEx TAS 07.0003X Exia IIC T4 (Ta =55°C)

IP66

2 Years on sensor and electronics for O₂, CO & H₂S

1 year on all other sensors

65-1010-xxx (xxx is gas type, eg. CO or H₂S)

65-1011-xxx (xxx is gas type, eg. CO or H₂S)

Barriers:

57-9010-01 IS Barrier Zenner less than 100 Ohm (4100R controller only)

57-9010-02 IS Barrier and repeaters +100 Ohm load

** 2 years on O₂, CO, H₂S and electronics

** 1year on all other sensors

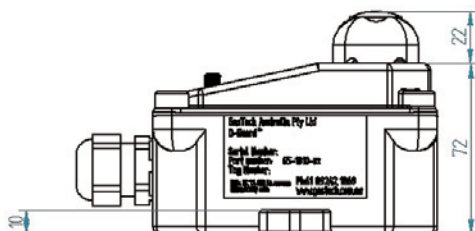

Distributed By

HEAD OFFICE

Telephone +61 8 6108 0000

Facsimile +61 8 9408 1868

Email info@gastech.com.au

24 Baretta Road

Wangara, Western Australia 6065

NSW OFFICE

Telephone +61 2 9451 0054

Facsimile +61 2 9450 0833

Email info@gastech.com.au

21/25, Narabang Way

Belrose NSW 2085

GASTECH
AUSTRALIA