



D-Guard™

Digital Guard Intrinsically Safe Intelligent Gas Detector

Part Number 65-1010xxx

Manual Revision v2.10 (updated 10 September 2012)

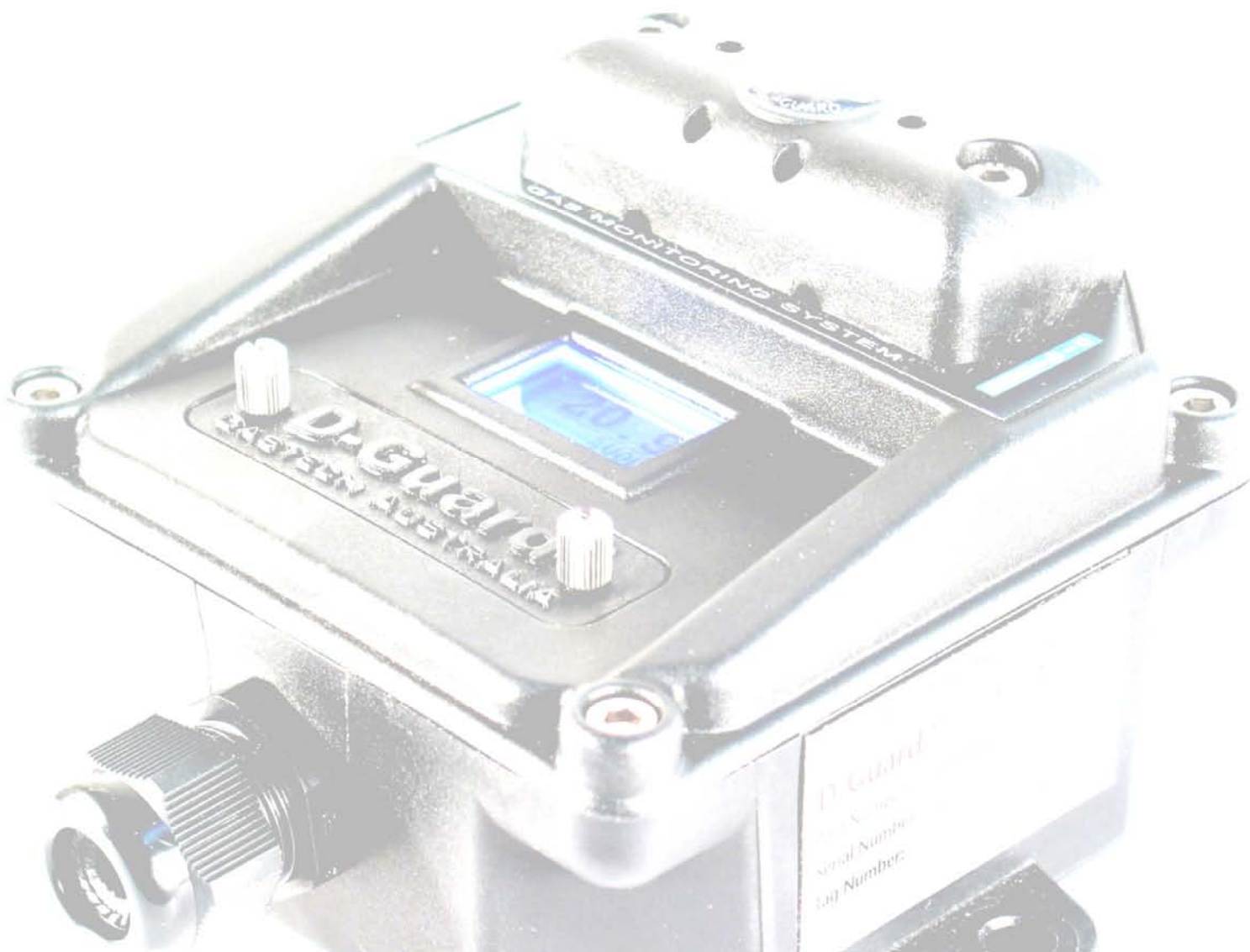

Table of Contents

1	Introduction	6
1.1	Features.....	6
2	Installation	7
2.1	Mounting.....	7
2.2	Opening The Enclosure.....	8
2.3	Wiring.....	9
2.3.1	Connection to Controller	9
2.3.2	Connection to Barriers.....	10
2.3.3	Optional Relay Board	12
2.3.4	Optional Siren and Strobe Light.....	15
2.4	Operation	16
3	Advanced Setup	17
3.1	Changing the PCB or Sensor	17
3.2	PCB Jumpers and Calibration	21
3.2.1	Isolate Mode.....	21
3.2.2	Normal/Invert Jumper	22
3.2.3	Sensor Bias Jumper	23
3.2.4	Sensor Bias Voltage Adjustment Trimpot.....	24
3.2.5	Shorting Link Jumper	25
3.2.6	Display Current Calibration Trimpot.....	26
3.2.7	Oxygen Load Jumper.....	26
3.3	Software Configuration and Calibration.....	27
3.3.1	Configuration	27
3.3.2	Calibration.....	32
APPENDIX I.	Troubleshooting.....	37
APPENDIX II.	Factory Setup	37
	Calibrating Zero/Full Loop Current.....	37
APPENDIX III.	Spare Parts List.....	40
APPENDIX IV.	Specifications	41
APPENDIX V.	IECEX Certificate.....	42

PROPRIETARY STATEMENT

GasTech Australia owns proprietary rights in the information disclosed within. By receiving this document, the recipient agrees that neither this document nor the information disclosed within nor any part shall be reproduced or transferred to other documents or used or disclosed to others for manufacturing or for any other purpose except as specifically authorised in writing by **GasTech Australia**.

COPYRIGHT STATEMENT

Information contained in this document is protected by copyright. No part of this document may be photocopied, reproduced, or translated to another program or system without prior written authorisation from **GasTech Australia**.

TRADEMARK STATEMENT

Protected through use and/or registration in the United States and many foreign countries are the trademarks and service marks of **GasTech Australia**. The use of the ® symbol indicates registration in the United States only and the "™" is in Australia; registrations may not have been issued at present in other countries. All other product names and logos are trademarks of their respective owners.

DISCLAIMER

Under no circumstances will **GasTech Australia** be liable for any claims, losses, or damages resulting from or arising out of the repair or modification of the equipment by a party other than **GasTech Australia** or its authorised service representatives, or by operation or use of the equipment other than in accordance with the printed instructions provided by **GasTech Australia** or if the equipment has been improperly maintained or subject to neglect or accident. Any of the foregoing will void the warranty.

REVISIONS TO MANUAL

All information contained in this manual is believed to be true and correct at the time of printing. However, as part of its continuing efforts to improve its products and their documentation, **GasTech Australia** reserves the right to make changes at any time without notice. Any revised copies of this manual can be obtained by contacting **GasTech Australia**.

SERVICE POLICY

GasTech Australia maintains an instrument service facility at the factory as well as authorised service facilities around the world. Should your instrument require service, you may contact us toll free at 1800 999 902 within Australia only or 61-8-9242-1869, or visit our website www.gastech.com.au for authorised service locations.

For non-warranty repairs, you will need to provide a purchase order number. If you need to set a limit to the repairs costs, state a "Not to Exceed" figure. If you need a quotation before you can authorise repair costs, so state, but understand this will incur additional costs and may delay processing of the repair.

If you wish to set a limit to the authorised repair cost, state a "not to exceed" figure. GasTech Australia's policy is to perform all needed repairs to restore the instrument to full operating condition, including reactivation or replacement of all out-of-warranty electrochemical cells.

You may send the unit, freight prepaid, to: GasTech Australia Pty Ltd, 106 Westpoint Centre, 396 Scarborough Beach Road, Osborne Park 6017, Western Australia. Attn.: Service Department. Enclose the copy of your contact details. Pack the instrument and all its accessories (preferably in its original packing) and any special instructions. Repairs are warranted for 90 days from the date of shipment. Sensors have individual warranties.

Always include your address, purchase order number, shipping and billing information, and a description of the defect as you perceive it. If this is the first time you are dealing directly with the factory, you will be asked to provide credit references, prepay, or authorise COD shipment.

 **NOTE: GasTech Australia assumes no liability for work performed by unauthorised service facilities.**

WARRANTY STATEMENT

1. Consumers have the benefit of conditions and warranties implied by the Trade Practices Act 1974 (TPA) and similar provisions of State and Territory enactments and nothing in these conditions is intended to exclude, restrict or modify any statutory obligation of GASTECH AUSTRALIA PTY LTD (Company) if that cannot lawfully be effected.
2. This warranty relates only to Equipment manufactured and services supplied by the Company, its related corporations and subsidiaries. Equipment or any part thereof which is returned to the Company, transportation prepaid, within 15 months from the date of dispatch from the Company's premises or 12 months from the date of shipment to the ultimate user (whichever occurs first) and is found by the Company, after examination, to be defective in workmanship or materials, will be either repaired or replaced as determined by the Company, free of charge. The terms of this paragraph apply unless stated otherwise in this instruction manual.
3. This warranty does not apply to:
 - a) replacement or repairs which are required as a results of improper installation, misuse, maladjustment modification or lack of routine maintenance by others;
 - b) items subject to deterioration or consumption in normal service, that is, those which must be cleaned, repaired or replaced routinely such as (but not limited to) lamps, bulbs and fuses, pump diaphragms and valves, absorbent cartridges, filter elements and batteries; or
 - c) goods, materials or parts supplied or manufactured by unrelated third parties and provided to the Purchaser at the specific request of the Purchaser and such goods, materials or parts will be repaired or replaced only to the extent of the original suppliers warranty.
4. Should the Company be liable for breach of a condition or warranty (other than the pursuant to section 69 of the TPA) implied by Division 2 of Part V of the Act (other than that implied by section 69 of the TPA) the liability of the Company for such breach shall, subject to section 68A(2) of the TPA, be limited to one of the following as determined by the Company.
 - a) the replacement of the Equipment or the supply of equivalent Equipment,-
 - b) the payment of the cost of replacing the Equipment or of acquiring equivalent Equipment.
5. Subject to Clauses 2 and 4 and any legislation to the contrary:
 - a) representatives and agreements not expressly contained herein shall not be binding upon the Company as conditions, warranties or representations; all such conditions, warranties, and representations on the part of the Company, whether express or implied, statutory or otherwise, whether collateral or antecedent or otherwise are hereby expressly negated and excluded;
 - b) the Company shall be under no liability to the Purchaser for any loss (including but not limited to loss of profits and consequential loss) or for damage to persons or property or for death or injury caused by any act or omission (including negligent acts or omissions) of the Company or the Company's agents, wherever occurring, arising from the subject matter of this agreement;
 - c) the Purchaser shall indemnify the Company against any claims made against the Company by any third party in respect of any such loss, damage, death or injury as is set out in sub-paragraph b) hereof; the Purchaser further agrees to indemnify the Company against all losses and expenses which the Company may suffer or incur due to the failure of the Purchaser fully to observe its obligations under this contract; and
 - d) no warranty is given and no responsibility is accepted by the Company to ensure the Equipment supplied complies with any statutory requirements relating to the marketing of goods. Compliance with such legislation shall be the sole responsibility of the Purchaser.
 - e) the Company specifically denies any liability for the overall performance of any plant or the results of any process with which the Equipment is integrated.

MANUAL CONVENTIONS

This instrument is designed to detect one or more of the following: flammable vapours, oxygen content and/or toxic gas and to give warning before they reach harmful levels. In order to ensure that it will warn of dangerous concentrations, it is essential that the instructions in this manual, particularly those concerning start up, operation, calibration, and maintenance, be read, understood, and followed.

Notices are used in this operator's manual to alert you to hazardous conditions to person or instrument and to notify you of additional information. This operator's manual uses the following notices.

 **NOTE:** Notifies you of additional information.

 **CAUTION:** Notifies you of potential damage to equipment.

 **WARNING:** Notifies you of potential danger that can result in personal injury or death.

Introduction

GasTech Australia is proud to introduce the next step in fixed gas detection equipment. The D-Guard™ (Digital Guard) is an intelligent gas detector which is designed around the operators requirements. Easy to calibrate, easy to set up, and highly stable, fixed-point toxic and Oxygen gas detector.

The D-Guard™ is an industry standard two wire 24VDC 4-20mA device.

1.1 Features

- Non intrusive calibration
- No alarms during calibration
- One PCB card for all gases detected
- No tool calibration
- Sensor drift elimination program
- Long-term sensor drift elimination program
- Permanent back light
- Fail-safe mode
- Non corrosive housing
- High impact housing
- Splashguard standard supply
- IP66 design
- IEC EX ia IIC T4



Installation

⊗ WARNING: Perform all installation procedures in a fresh air environment (known to be free of combustible and toxic gas and having normal oxygen content). The D-Guard™ is not in operation as a system until the start up procedure is complete.

2.1 Mounting

📄 NOTE: The packing slip indicates the serial number of your D-Guard™. The serial number is also on a label on the side of the D-Guard™. Please record the serial number on the front of this manual.

The installation should be in the area with most potential to detect the gas as quickly as possible. Take note of the gas density as this will help in finding the best location for the D-Guard™. For example, heavier gases like H₂S would have the sensor mounted lower than for Hydrogen which is a lighter gas.

Securely mount the unit to the wall using wall plugs and screws. Dimensions of the two mounting holes on the D-Guard enclosure are shown below.

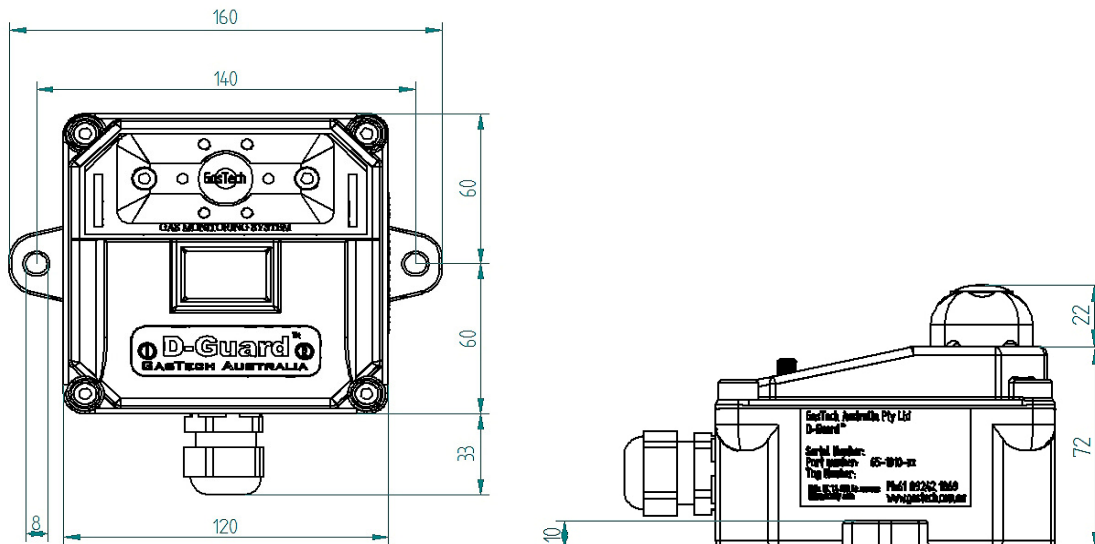

2.2 Opening The Enclosure

In order for power to be connected inside the unit, the enclosure must be opened.

1. Remove the 4 housing lid screws (4mm Alan key). The screws are held in with "O" rings to stop them falling out and losing them.



2. Gently remove the lid making sure that you don't lose the 4 lid screws or the large "O" ring that seals the lid to the base.

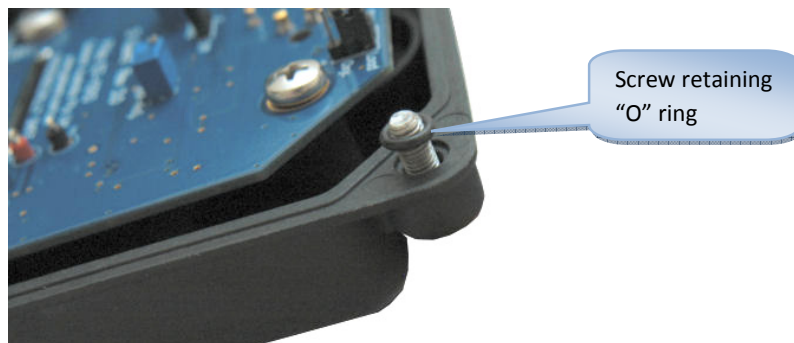

3. Turn over the lid to find the green power connector.

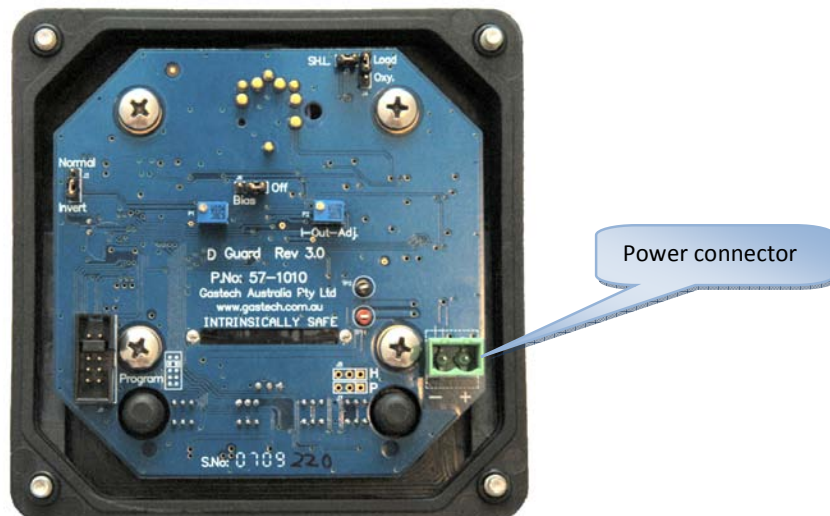

4. Run the power cables via the grommet to the green connector as described in the next section.
5. Once the wiring is complete, confirm that the housing sealing "O" ring is fitted and in good condition.

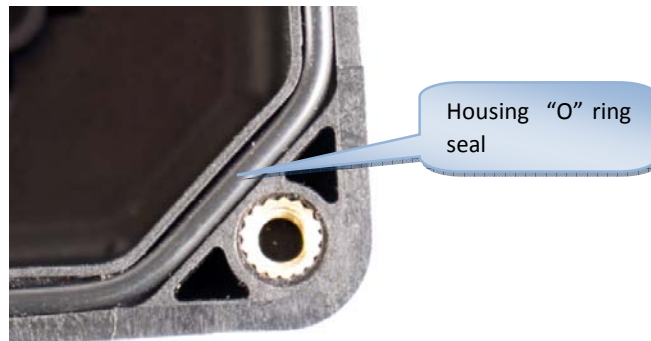

6. Fit lid and tighten the 4 screws using a 4mm Allan key tightening the housing evenly.

2.3 Wiring

The D-Guard™ sensor can be used with any standard 2 wire, 4 to 20 mA 24VDC controller. Typical controllers include the GasTech Australia Micro Rack™.

Located on the PCB, bottom right corner there is a two pin removable plug. Ensure the positive and negative wires are terminated with the correct polarity, which is marked on the PCB.

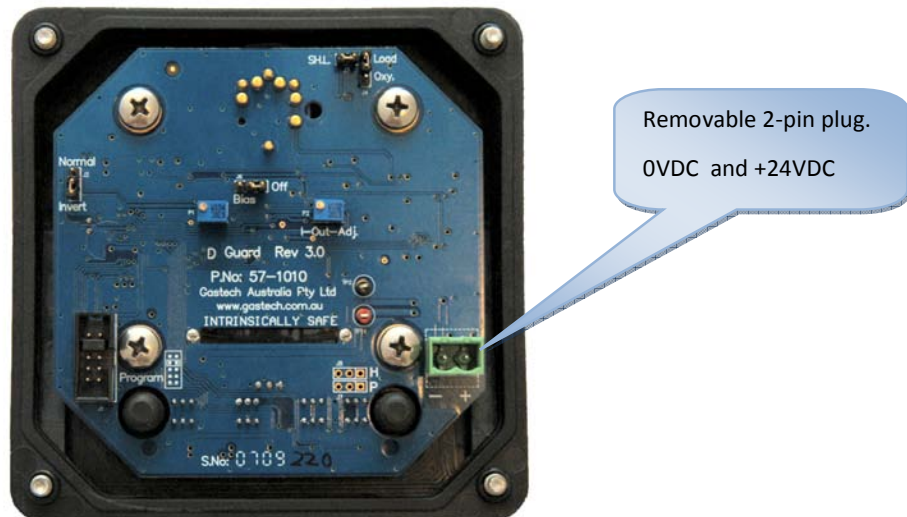

2.3.1 Connection to Controller

When connecting a D-Guard™ unit to a controller such as the GasTech 4100R controller, follow the pinouts as outlined below. Other third party controllers are also connected in the same manner.

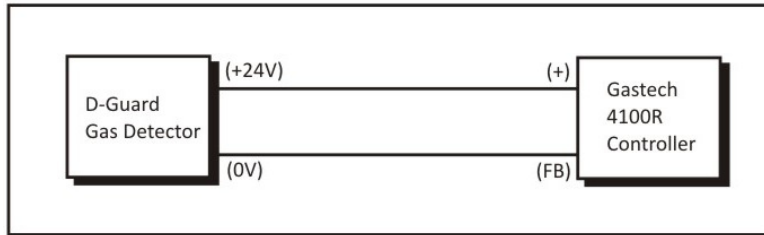

2.3.2 Connection to Barriers

Intrinsic safety barriers are devices that limit the current, voltage, and total energy delivered to a sensor in a hazardous area or flammable environment in order to prevent an explosion.

The barriers designed to protect the system must be mounted outside of the hazardous area in an area designated as Non-hazardous or safe in which the hazard is not and will not be present.

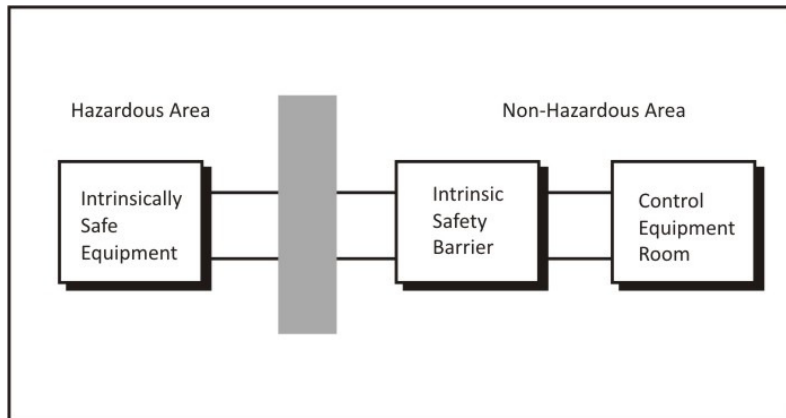

If you are utilizing the D-Guard™ in a Hazardous environment, you will need to select an appropriate IS barrier.

Selection of the type of barrier requires consideration of the voltage drops that occur in the system. As the D-Guard requires a minimum of 12VDC to operate, the voltage drops in the barrier system, controller load resistor and cabling cannot exceed the power supply voltage less 12VDC.

- ⊗ **WARNING: Installers should consult the Intrinsically Safe Barrier manufacture and refer to IEC Intrinsically Safe System Standard IEC 60079-25:2003 or AS/NZS 60079.25:2004 before selecting a suitable barrier.**
- ⊗ **A D-Guard operated without a barrier will require the D-Guard to be inspected by the manufacture to confirm that none of the safety components have been damaged.**

GasTech recommend the GasTech 57-9010-02 barrier (KFD2-STC4-Ex1) for most systems. This barrier will work on all controllers at 24VDC.

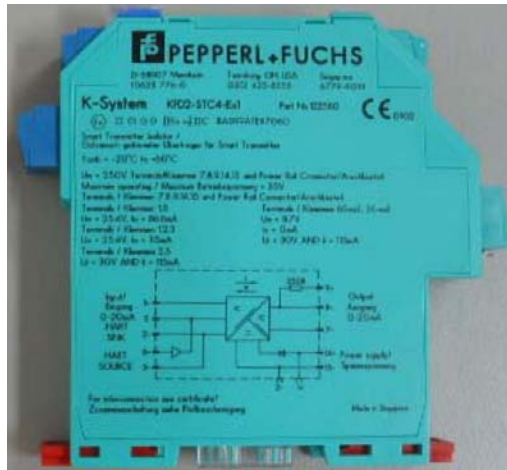

Wiring of the GasTech 57-9010-02 barrier is as follows:

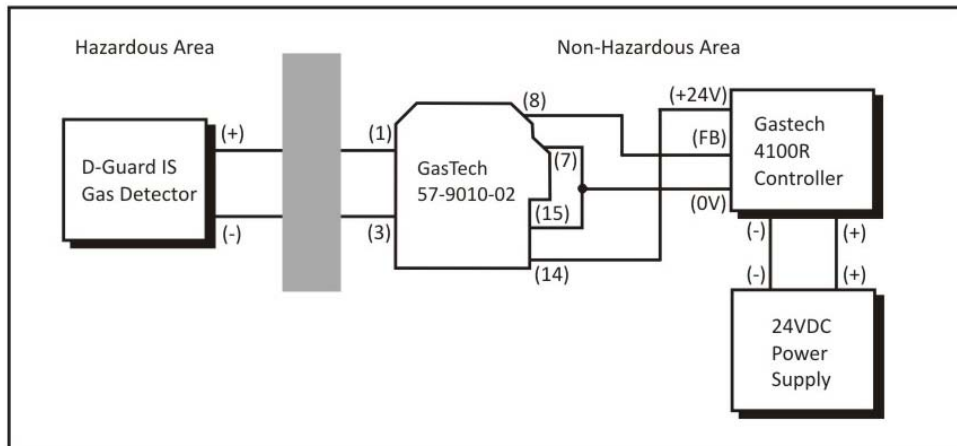

A second barrier that can be used is the GasTech 57-9010-01 (MTL 7787+). This barrier must only be used in conjunction with the GasTech 4100R controller card, as the 4100R card has 100Ω load.

⊗ WARNING: If you use this barrier on another controller that uses a load above 100ohms the D-Guard will turn off when it see a high gas reading (>15mA) as the volt drop over this barrier is greater.



Wiring of the GasTech 57-9010-01 barrier is as follows:

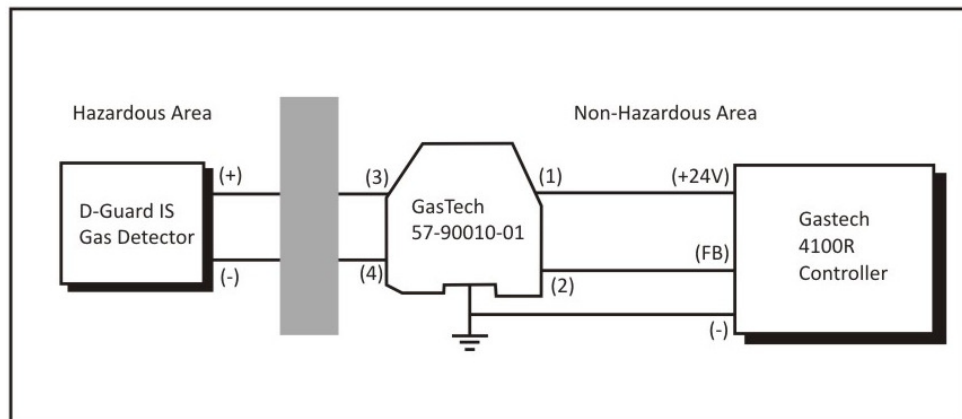

2.3.3 Optional Relay Board

The D-Guard™ can be ordered with an optional relay board (Part number: 65-1011-xxx) which allows the D-Guard™ to operate as an independent unit.

⊗ WARNING: If the D-Guard is used with the relay board, the unit is no longer Intrinsically Safe, even if used in conjunction with an IS barrier.

The image below shows various connectors on the relay PCB.

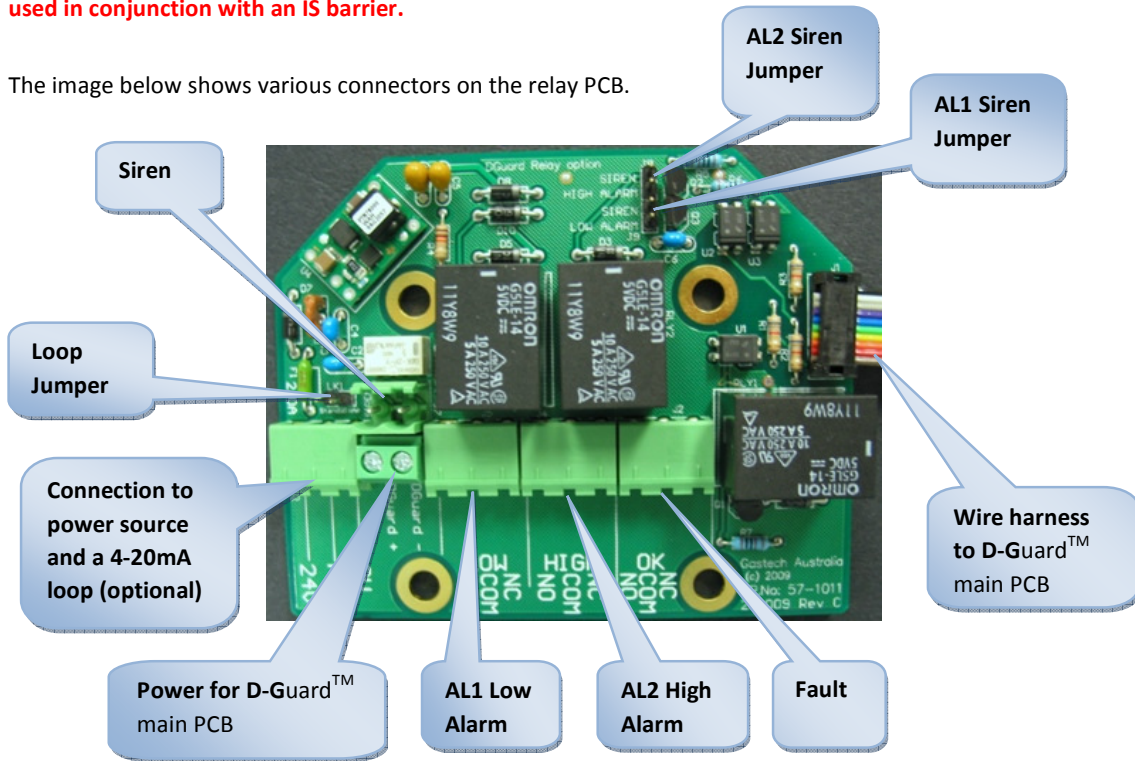

The function of the various connectors is as follows:

Feature	Description
24V	Connect this to the positive side of the power supply. Supplies power to the relay board as well as the D-Guard™ main PCB.
FB (feedback)	Current source loop output, for connection to an external controller
0V	Connect this to negative side of the power supply
DG+	This needs to be connected to the + connector on the D-Guard™ main PCB.
DG-	This needs to be connected to the - connector on the D-Guard™ main PCB.
AL1 Low Alarm	This relay is energized when AL1 is active. This alarm point is adjustable in software as described in the next section.
AL2 High Alarm	This relay is energized when AL2 is active. This alarm point is adjustable in software as described in the next section.
Fault Relay	This relay is normally energized. It becomes de-energized when there is a sensor failure, power failure or when the D-Guard™ is in Isolate mode.
Loop Jumper	This jumper connects the FB and 0V lines together. It allows the D-Guard™ main PCB to operate in standalone mode where a system controller is not present
Siren	This is connected to the factory fitted Sounder & Strobe on D-Guard-S units only
AL1 Siren Jumper	This jumper, when installed enables the Siren output to become active when an AL1 Low Alarm is active.
AL2 Siren Jumper	This jumper, when installed enables the Siren output to become active when an AL2 High Alarm is active.

⚠ CAUTION: The relay contacts are rated at 5A @ 48VDC max. Mains connection is not permitted.

The D-Guard™ with relay option is normally used in standalone mode, however it can still be connected back to a controller such as the Gastech 4100R. The diagram below shows how the units are wired together.

📄 NOTE: In this configuration, the jumper on the relay PCB must be removed.

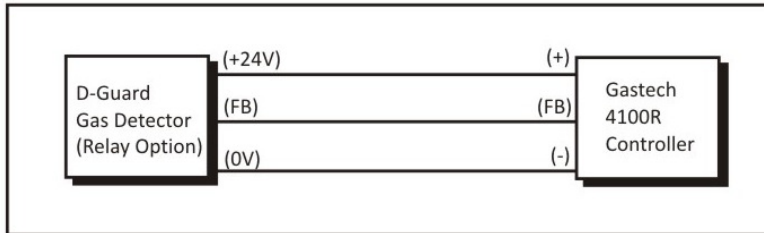

Internal Connection diagrams:

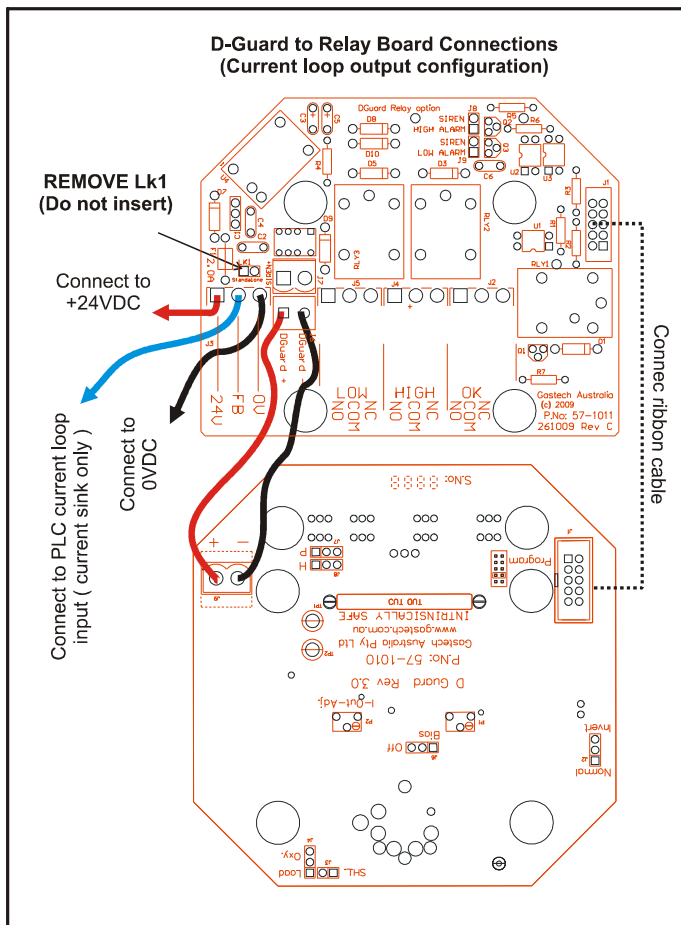

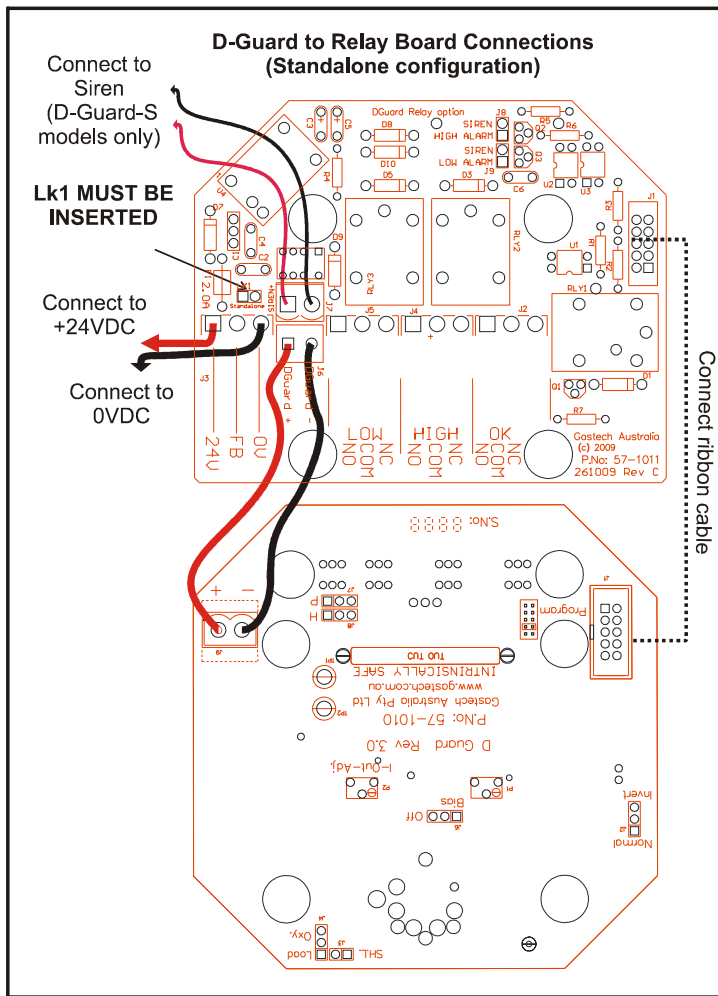

2.3.4 Optional Siren and Strobe Light

The D-Guard™ can be ordered with an optional sounder & strobe in addition to the relay board (Part number: 65-1012-xxx) which allows the D-Guard™ to operate as a complete gas detection & alarm indication unit.

⊗ WARNING: If the D-Guard is used with the sounder and strobe, the unit is no longer Intrinsically Safe, even if used in conjunction with an IS barrier.

The image below shows a D-Guard with a factory fitted Sounder and Strobe.



2.4 Operation

Complete the following procedures to place the D-Guard™ into normal operation.

1. Complete the mounting and wiring procedures described in the previous sections
2. Complete all installation procedures described in this manual
3. Verify that all wiring connections are correct and secure
4. Check power being supplied to the unit is correct (24VDC)
5. Turn on the incoming power at the power source

 **NOTE:** The D-Guard™ starts up in a warm-up Isolated mode with the mA locked at 3mA for 90 seconds while the sensor stabilised and the D-Guard™ program initialises and completes a series of function tests.

After the start up procedure and all tests are completed if operating is within tolerance the display will go into normal operating mode, the mA will be released and the system will then be functioning. The LCD screen shows the status of the system.

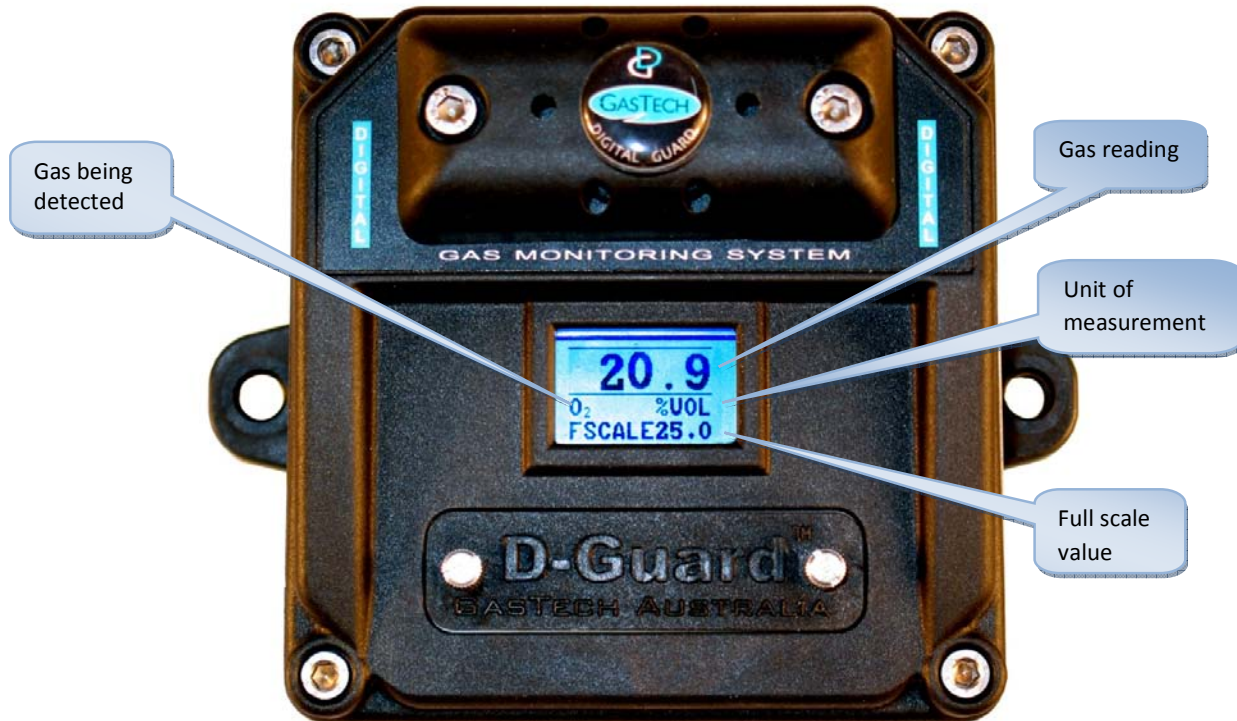

Advanced Setup

One of the key features of the D-Guard™ is its ability to be easily serviced and calibrated in the field. The unit will need to be calibrated and/or reconfigured if you are performing any of the following tasks:

- Replacing a PCB
- Replacing a sensor
- Changing to a different sensor
- Scheduled calibration or maintenance
- Reactivation after prolonged shutdown

All calibration values are stored in the D-Guard™ non volatile memory but as no monitoring of the sensor operation is performed during the shutdown period the sensor might have been poisoned and might not respond as expected.

3.1 Changing the PCB or Sensor

1. Isolate the sensor back at the control panel so an open circuit fault will not trip or create any alarms.
2. Remove the 4 housing lid screws (4mm Hex or Allan Key). The screws are held in with “O” rings to stop them falling out and losing them.

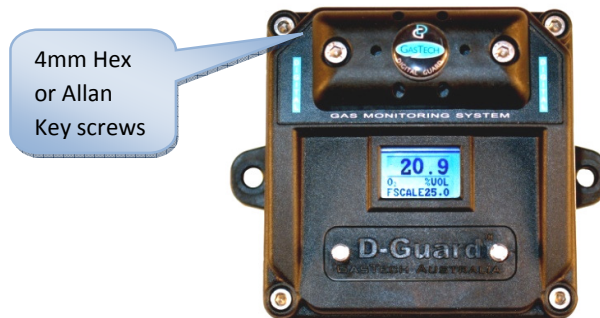

3. Gently remove the lid making sure that you don't lose the 4 lid screws or the Large “O” ring that seals the lid to the base.

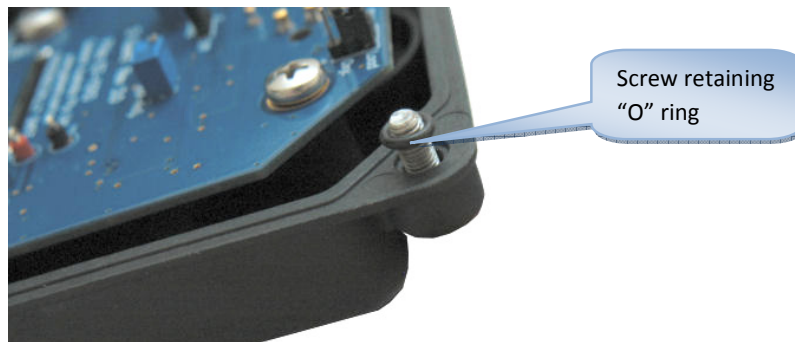

4. Turn over the lid and remove the green power connector and the D-Guard™ will power down. The display will go blank and the back light will turn off.

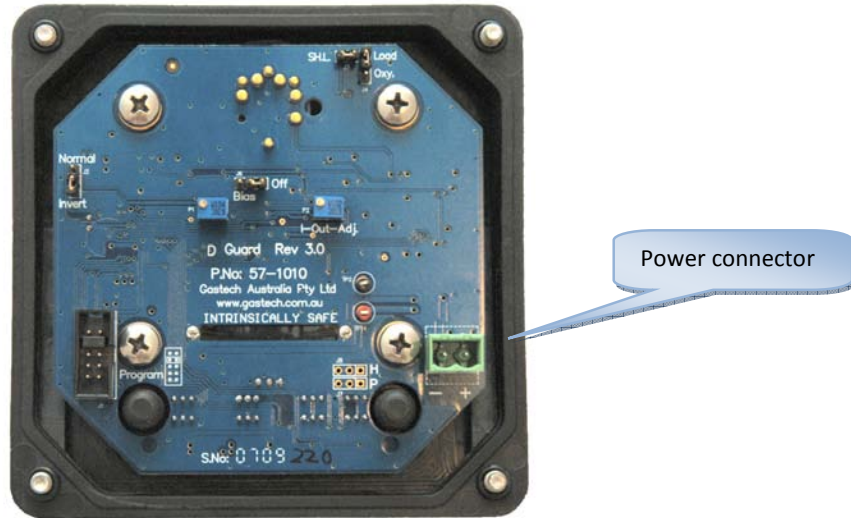

5. Move to a clean location
6. Gently remove the 4 Phillips head screws holding the PCB in place

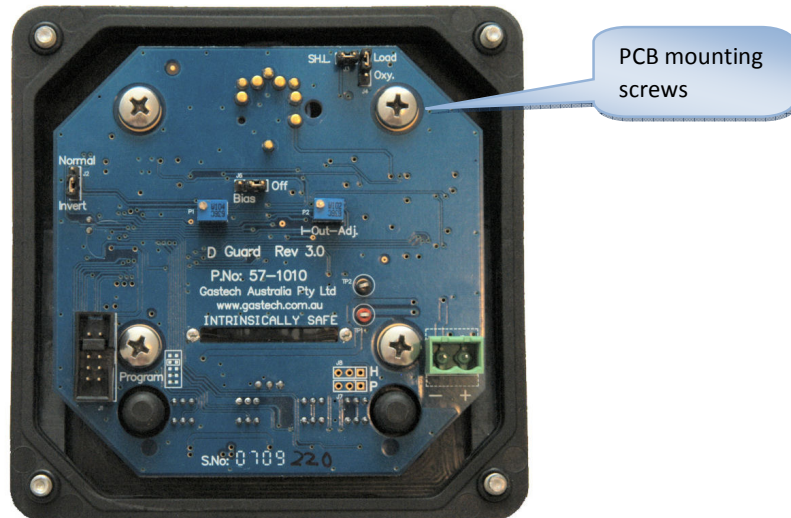

7. Gently remove the PCB which will expose the sensor.

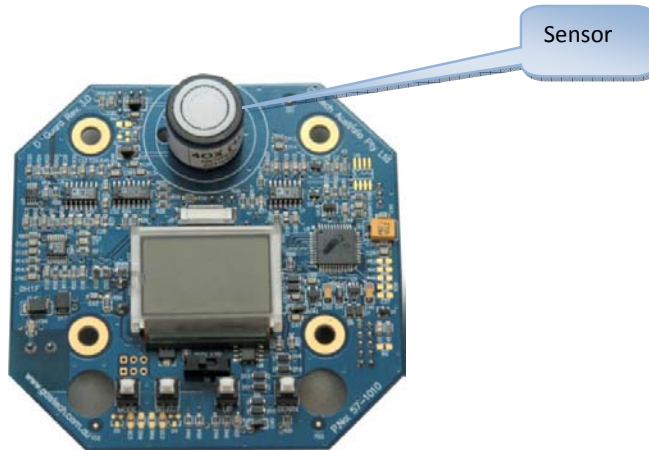

8. If you are replacing the PCB, gently remove the sensor and install it into the new PCB. The sensor will pull apart from the PCB. (Take note of orientation of pins to help on the reinstallation of new sensor – it will only go in one way)
9. If you are replacing the sensor, remove the old sensor and plug in the new one. Confirm the new sensor is the same as the old sensor.

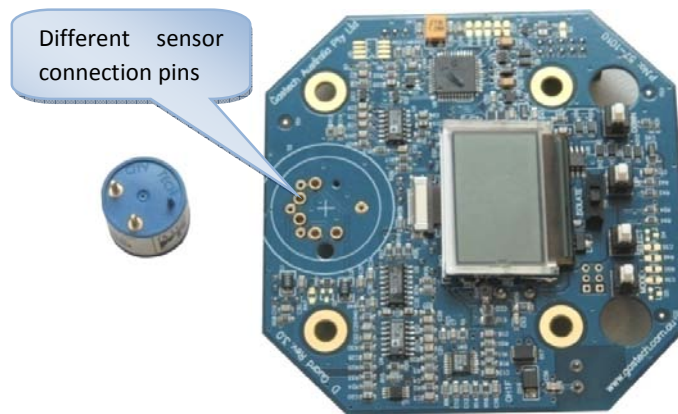

10. Gently press the new sensor back into place.
11. If replacing a sensor, you should also replace the sensor filter and gasket at the same time.
12. The sensor filter and gasket need to be ordered separately to the sensor.

 **Note: The sensor filter part number is 33-9998 and the gasket part number is 07-1010-01**

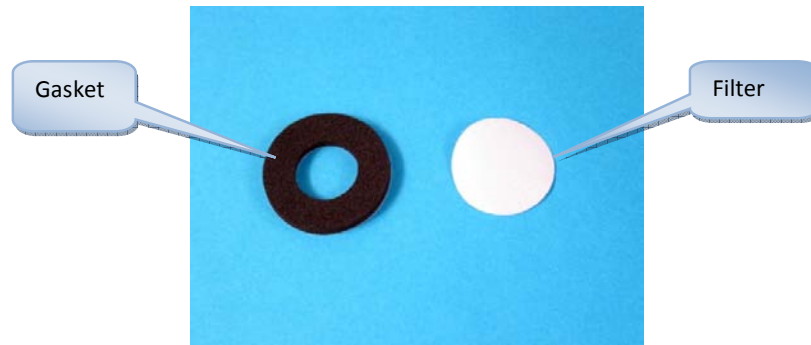

13. Remove the old gasket with a small screw driver. The gasket has double-sided tape holding the filter and gasket in place.

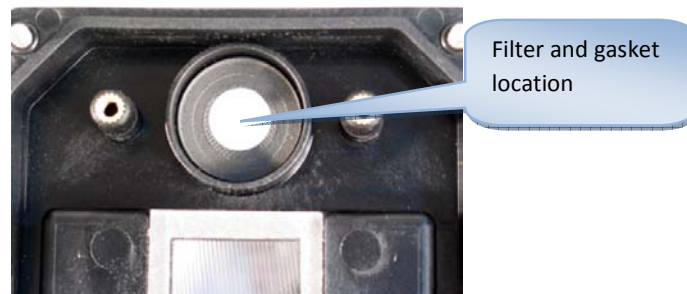

14. Fit new gasket and filter the same way as previously fitted. Use the sticky side to stick to the plastic enclosure.

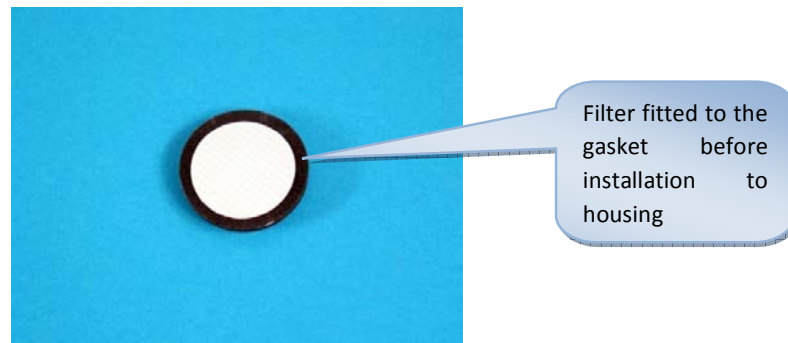

15. Gently fit the PCB with new sensor back onto the lid and gently tighten the 4 Phillips head screws until the PCB comes flush with the mounting posts.
16. If you have just replaced the PCB, or have replaced the sensor with a different model, skip to the next section as the PCB may need some jumper or calibration settings changed.
17. If you are replacing the sensor with the exact same model as previous, the enclosure can be screwed back together as follows

18. Reconnect the power socket to the PCB and ensure the unit powers up.
19. Confirm that the housing sealing “O” ring is fitted and in good condition

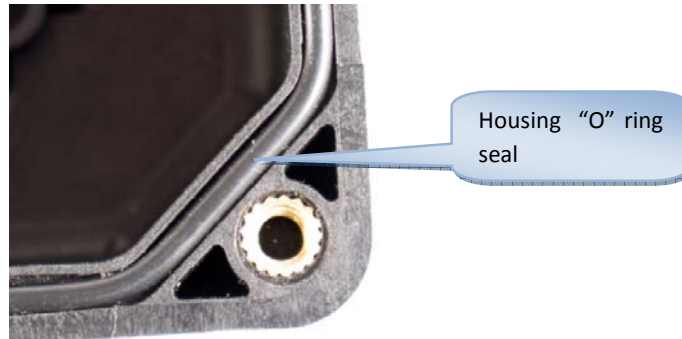

20. Fit lid and tighten the 4 screws using a 4mm Allan key tightening the housing evenly.
21. Recalibrate the sensor as per the “Software Configuration and Calibration” section later in this manual.

3.2 PCB Jumpers and Calibration

If fitting a replacement PCB or changing the sensor to a different model, there are some hardware jumpers and trim-pots that may need adjustment. Before proceeding, make sure the sensor is isolated to prevent any false alarms.

3.2.1 Isolate Mode

The isolate mode of the D-Guard™ is a feature which you can isolate the sensor for maintenance or if the sensor has an extended stabilization period. First, open the calibration plate by unscrewing the two thumb screws on the calibration plate.

 **Note:** The plate is designed to pivot on the left screw. The screws are different length and will stay connected to the plate. The screws are captive to the plate but can be fully removed. Don't fully remove the screws as you may lose them.

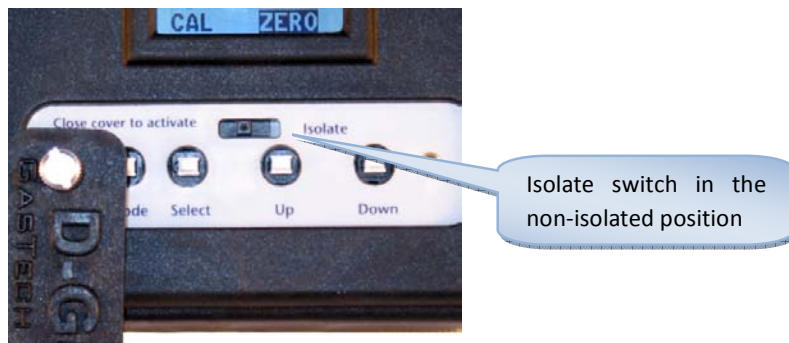

Flicking the Isolation switch over to “ISOLATE” will drop the mA signal down to 3mA and invert the display, the gas reading will flash, and the word “ISOLATED” is shown. This mode is permanent until the switch is changed over.

 **Note:** No gas readings will be transmitted in the “ISOLATE” mode.



3.2.2 Normal/Invert Jumper

This jumper is set to invert for Oxygen sensors and any other sensor that has a reducing sensor output. Contact the factory for confirmation on the sensor that is being fitted. The table below lists some common sensors which require the jumper set to invert mode.

Gas	Sensor Model	GasTech Part Number
Chlorine	4CL	65-8009-4CL
	7CLH	65-8009-7CLH
Nitrogen Dioxide	4ND	65-8004-4ND
	7NDH	65-8004-7NDH
Ozone	7OZ	65-8005-7OZ
Chlorine	Cl2 3E 10/50	65-9097-CL2-1
		65-9097-CL2-2
Chlorine Dioxide	ClO2 3E 1	65-9097-CL02
Fluorine	F2 3E 1	65-9097-F2
Hydrogen Fluoride	HF 3E 10 & HF 3E 10S	65-9097-HF
Nitrogen Dioxide	NO2 3E 50	65-9097-NO2
Ozone	O3 3E 1	65-9097-O3-2

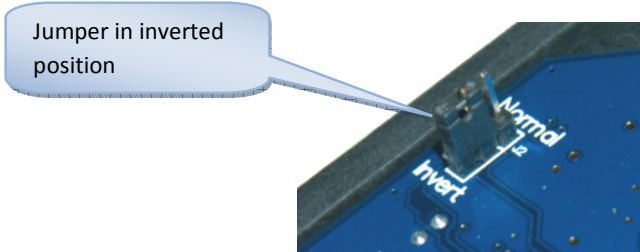
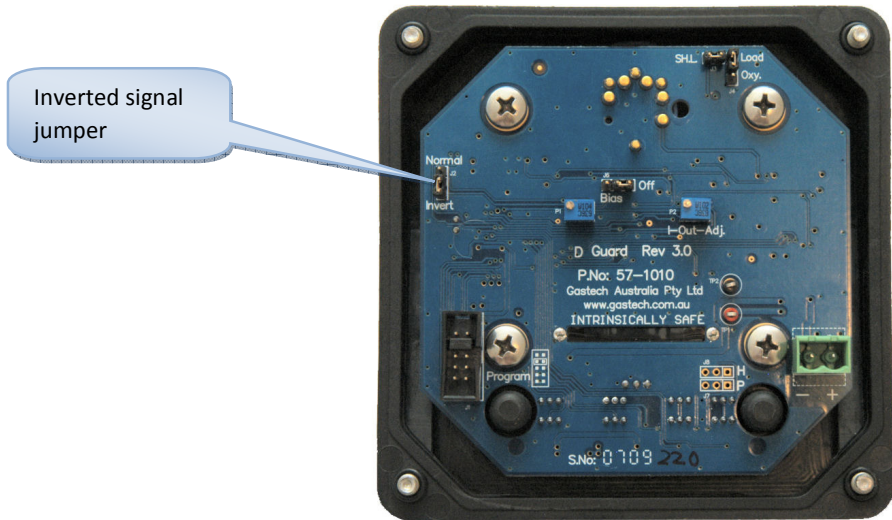

3.2.3 Sensor Bias Jumper

This jumper should be in the off position for all sensors, except sensors needing a Bias voltage. The table below lists some common sensors that require a bias voltage. If you are replacing a sensor for a different gas, the bias voltage may need to be adjusted by the adjustment pot as described next.

Sensor Model	Bias Voltage	GasTech Part Number
HCL 7HL	300mV	65-8011-7HL
NO 4NT	300mV	65-8002-4NT
NO 7NT	300mV	65-8002-7NT
ETO 7ETO	300mV	65-8013-7ETO
HCL 3E 30	200mV	65-9097-HCL/HBR
NO 3E 100	200mV	65-9097-NO
THT 3E 100	150mV	65-9097-THT

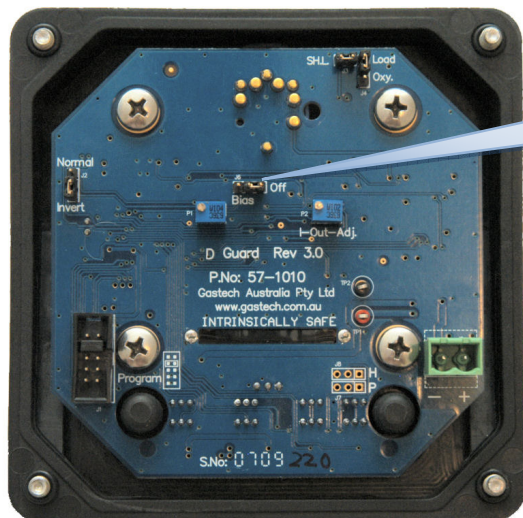

Sensor bias jumper



Sensor bias jumper in off position

3.2.4 Sensor Bias Voltage Adjustment Trimpot

⚠ CAUTION: This trimpot is set by the factory on delivery. Do not adjust it as it can burn out the sensor and void warranty. If you are setting up the board for a different sensor that needs to adjust the bias voltage please contact the factory before hand to confirm the procedure.

1. Measure the millivolts across the reference and sensing sockets on the PCB as shown below.
2. Adjust the Bias trimpot to the required Bias voltage.
3. The Bias jumper must be in the "On" position and the shorting link must be removed.

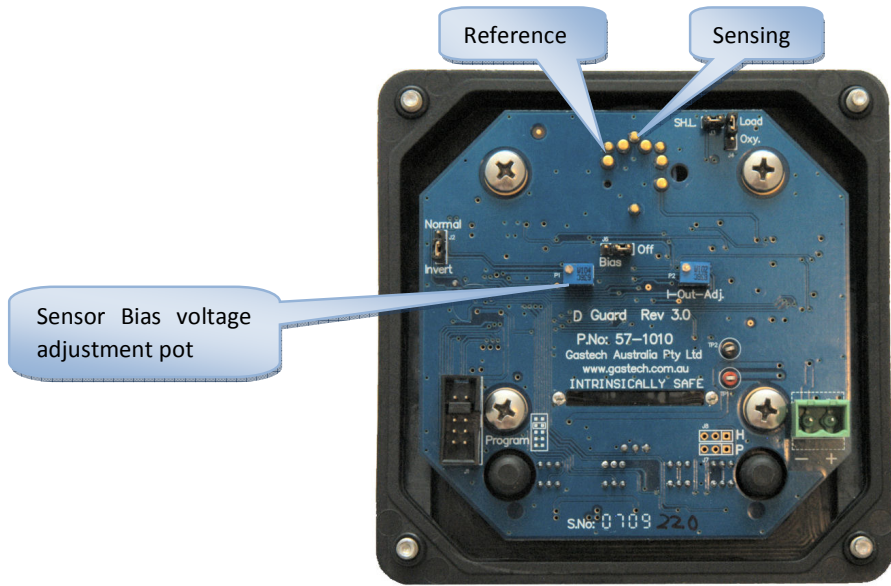

3.2.5 Shorting Link Jumper

The shorting link will be installed on all non bias sensors.

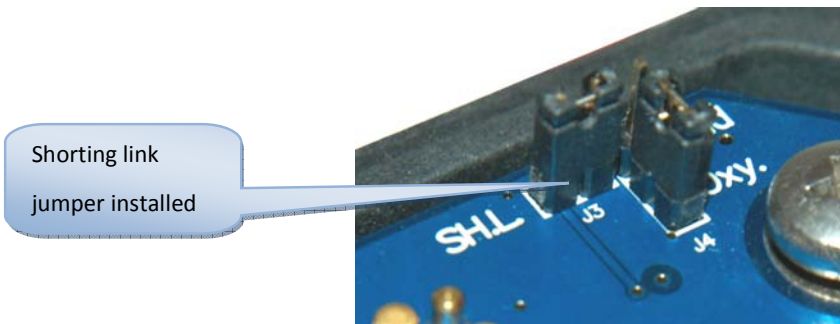
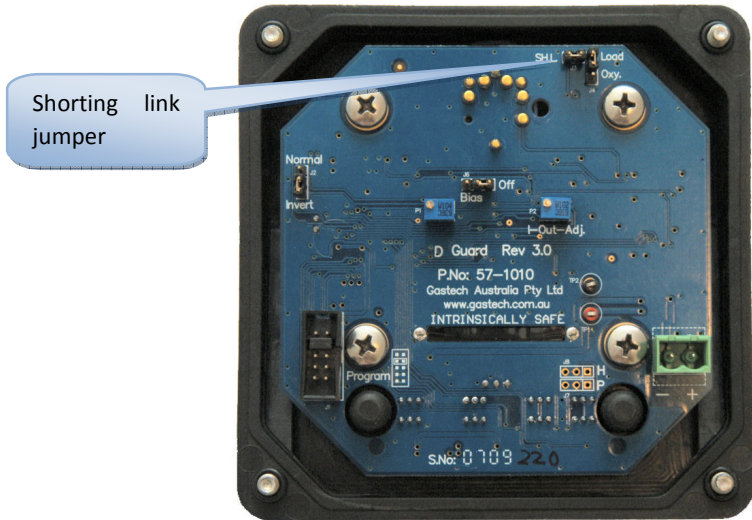

3.2.6 Display Current Calibration Trimpot

This trimpot is factory set and should not need adjusting. See the Appendix for more information.

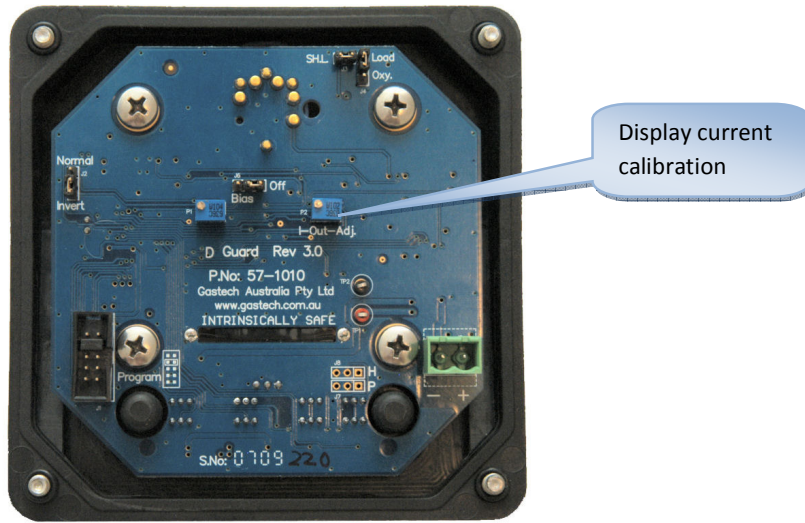

3.2.7 Oxygen Load Jumper

This jumper is only applicable for an Oxygen sensor. It will be in the down position for an Oxygen sensor and up for all other sensors.

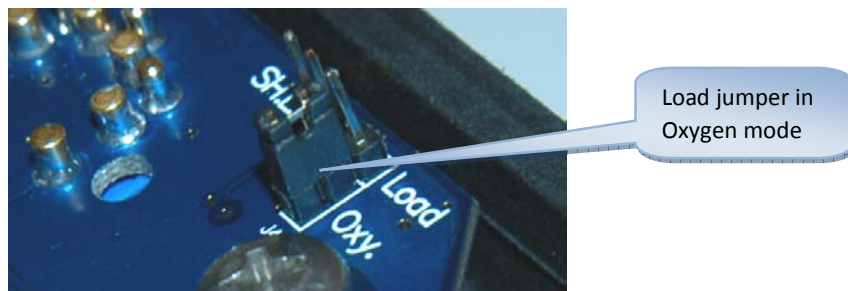
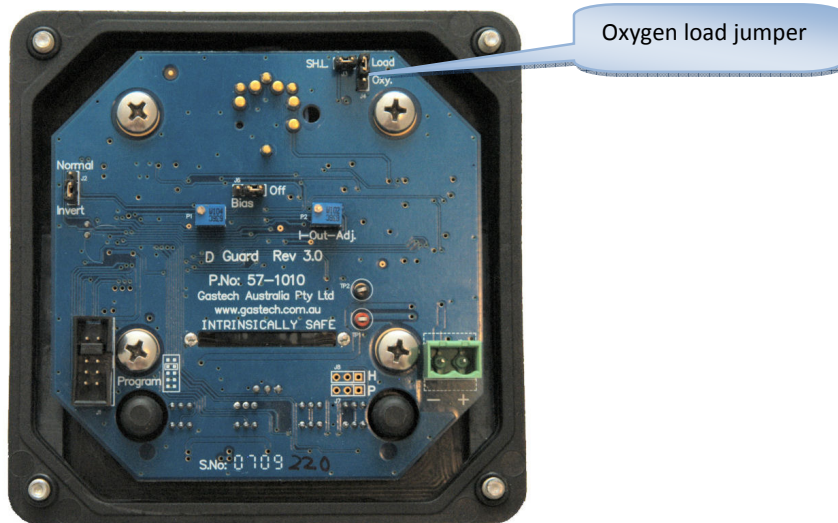

The table below shows the settings for the various GasTech oxygen sensors.

Sensor	GasTech Part Number	Normal Invert Jumper (J2)	Shorting Link (J3)	Oxygen Load Jumper (J4)	Sensor Bias Jumper (J6)	0-25% Range Gain Setting
7OX (V)	65-8000-7OXV	Invert	Off	Oxygen	Off	G 3
4OX (1)	65-8000-4OX1	Invert	Off	Oxygen	Off	G 3
4OX (2)	65-8000-4OX2	Invert	Off	Oxygen	Off	G 5

3.3 Software Configuration and Calibration

3.3.1 Configuration

Once you have confirmed all hardware settings are correct, the enclosure can be closed as outlined in the previous section. The D-Guard™ will now need to be programmed and calibrated to the sensor you have fitted. This is achieved using the 4 buttons on the front panel.

1. Power up the D-Guard™. Open the calibration plate to enter calibration mode. To open the calibration plate, unscrew the two thumb screws on the calibration plate.

 **Note:** The plate is designed to pivot on the left screw. The screws are different length and will stay connected to the plate. The screws are captive to the plate but can be fully removed. Don't fully remove the screws as you may lose them.



2. Once the calibration plate is removed, the mode button will be released sending the unit into calibration mode.

 **Note:** Having the calibration plate open will lock the mA signal at 4mA or the equivalent mA for 20.9% oxygen if an oxygen sensor is fitted. This will prevent any alarms being generated when calibrating the D-Guard™.

Mode button is released when the calibration door is opened. No other user operation of this button is necessary



- The first menu the D-Guard™ enters in calibration mode, is the zero menu. This mode is used during calibration, which will be discussed later in this section.

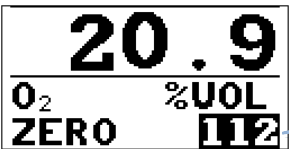

Zero calibration point

- Press the “Select” button to change to the span calibration point.



Span calibration point

- Once the D-Guard™ is in the span calibration mode you can then enter the set up mode by pressing and holding down the “Select” button for 3 seconds.
- You have now entered the set up mode. The first screen is the gas selection menu.

Selected gas



- Use the “Up” and “Down” buttons to toggle between the various gases until the matching gas is found. Press the “Select” button to move to the next menu, or press and hold the “Select” button for five seconds to load default calibration values for the selected sensor. The default calibration values are shown in the table below.

GAS	FSCALE	ALARM1	ALARM2	DP	CAL GAS	UNITS	GAIN
CL2	10.0	0.5	1.0	10.0	5.0	ppm	11
SO2	20.0	2.0	5.0	20.0	10.0	ppm	8
NO	100	25	75	100	50	ppm	6
NO2	20.0	2.0	5.0	20.0	10	ppm	8
HCN	50	4.7	10.0	50.0	10	ppm	11
H2S	100	10	15	100	25	ppm	3

GAS	FSCALE	ALARM1	ALARM2	DP	CAL GAS	UNITS	GAIN
CO	500	30	200	500	100	ppm	6
NH3	100	25	35	100	50	ppm	9
O2	25.0	19.5^	23.5	20.9	0.0	%VOL	3
O3*	2.00	0.1	0.3	2.00	1.75	ppm	9
PH3*	5.00	0.3	1.0	5.00	2.0	ppm	10
ETO*	20.0	1.0	5.0	20.0	5	ppm	6
HCL*	100	5.0	10.0	100	10	ppm	6

*These gas settings are available in new units with hardware version 3.1 or greater.

^When the gas type is Oxygen, ALARM1 is activated when the concentration drops below the AL1 setting.

8. If you need to change any of the default values, press the "Select" button to move to the next field.
9. The next screen is used to configure where the decimal point should be placed in the gas reading. Use the "Up" and "Down" buttons to select the correct position and press the "Select" button to move to the next menu.

20.9
O₂ DP %UOL 25.0

10. The next screen is used to set the full scale value (maximum value). Use the "Up" and "Down" buttons to change the value. Pressing the "Select" button will move along to the next digit. Repeat this procedure until the value is set and then press the "Select" button to move to the next menu.

20.9
O₂ DP %UOL FSCALE 25.0

11. The next screen is used to enable or disable alarms. Use the "Up" or "Down" button to toggle between on or off. Press the "Select" button to move to the next menu.

Note: Alarms should only be set to ON if the D-Guard is being used with the optional relay board installed. The relay board is discussed in the previous section.

20.9
O₂ DP %UOL ALARMS ON

12. If alarms are turned on, the next menu will prompt for a value at which alarm 1 (low) will be activated. Use the "Up" or "Down" button to change the value and the "Select" button to move to the next digit. Repeat this procedure until the value is set and then press the "Select" button to move to the next menu.

20.9	
O₂	%UOL
ALRM1	19.5

13. If alarms are turned on, the next menu will prompt for a value at which alarm 2 (high) will be activated. Use the “Up” or “Down” button to change the value and the “Select” button to move to the next digit. Repeat this procedure until the value is set and then press the “Select” button to move to the next menu.

20.9	
O₂	%UOL
ALRM2	23.5

14. The next screen is used to set the calibration gas value. Use the “Up” or “Down” button to change the value. Pressing “Select” will move along to the next digit. Repeat this procedure until the value is set and then press the “Select” button to move to the next menu.

20.9	
O₂	%UOL
CAL GAS	18.0

15. The next screen is used to set the gain for the sensor. Use the “Up” or “Down” button to set the correct gain value.

20.9	
O₂	%UOL
GAIN	G 3

16. Another way of determining the required gain is to look up the sensor sensitivity/output current from the manufacturer’s specification datasheet. Multiply the sensor output by the range of the detector. This will provide you with the “Calculated Full Scale Sensor Output”. Establish the correct gain setting using the table below.

Gain Setting	Factory Setup (Calculated Full Scale Sensor Output)
G 0	750 – 440 uA
G 1	440 – 290 uA
G 2	290 – 180 uA
G 3	180 – 130 uA
G 4	130 – 85 uA
G 5	85 – 60 uA

Gain Setting	Factory Setup (Calculated Full Scale Sensor Output)
G 6	60 – 40 uA
G 7	40 – 25 uA
G 8	25 – 17 uA
G 9	17 – 11 uA
G 10	11 – 7.0 uA
G 11	7.0 – 5.0 uA
G 12	5.0 – 3.5 uA
G 13	3.5 – 2.0 uA
G 14	2.0 – 1.5 uA
G 15	1.5 – 1.0 uA

 **Note:** If the correct gain setting is unknown, you can apply a span gas to the sensor and toggle the gain settings until you get a reading close to the span gas concentration. This option is not the preferred set up procedure and will only work on a new sensor that is working correctly. Having too much gain could result in excessive sensor drift or reduced sensor life.

17. Press the “Select” button to move to the next menu.
18. The next screen is used to set the unit of measurement. The sensor that is installed determines the units of measurements. Different gases are measured in “%VOL”, “ppm” or “%LEL”. Use the “Up” or “Down” button to toggle between the various options. Press the “Select” button to move to the next menu.

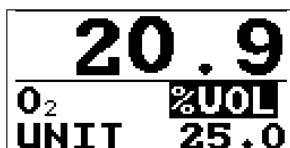

19. The next screen is used to enable or disable zero suppression. The ZSUPP function is part of the intelligent algorithms of the D-Guard™. The D-Guard™ advanced software monitors the sensor performance and small sensor drifts, which is a characteristic of all sensors. This drift is due to sudden temperature, humidity and pressure changes or aging sensors. The advanced electronics and software will remove this insignificant drift and keep the detector reading zero or 20.9 (for an Oxygen sensor). Use the “Up” or “Down” button to toggle between on or off. Press the “Select” button to move to the next menu.

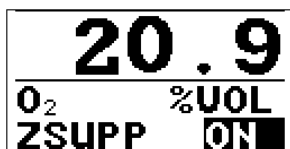

20. The next screen will depend on the type of gas the D-Guard™ is setup to detect. If the unit is configured for O₂, the menu will show autospan, for all other gases the menu will show autoz. This Atmospheric compensation menu is one of the most advanced features of the D-Guard™. This logic

monitors the sensor over a given time and calculates against a pre determined criteria which will then adjust the sensors base line to keep the sensor in accurate calibration and eliminate sensor drift which is a characteristic of all electrochemical sensors as they age. This feature prevents false alarms from drifting older sensors. Use the “Up” or “Down” button to enable or disable this feature. Press the “Select” button to move to the next menu.

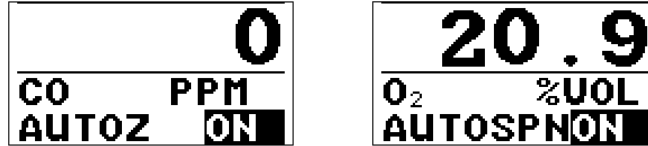

- The next screen is used to set the LCD contrast. The advanced LCD is temperature compensated and will automatically adjust through the normal operating range but can be manually tuned when operating in extreme conditions. Use the “Up” or “Down” button to adjust the contrast. Press the “Select” button to move to the next menu.



- The next screen is used to set the average. The D-Guard™ takes samples from the gas sensor every 20ms. This field determines how many samples are used to calculate the gas value. Typically this is set to 3 or 4, but if a sensor is fluctuating, the average can be set higher so that the response is slower. It can be set to 0 for no averaging. Use the “Up” or “Down” button to toggle between the various options 1-10 samples. Press the “Select” button to move to the next menu. This will bring you back to the calibration menu.



3.3.2 Calibration

To calibrate the D-Guard™ you will need certified calibration gas, which is in date and has a concentration between 25% and 50% of the full range of the detector, this is an Australian standard recommendation. Other concentrations are useable, but using lower concentrations could have an effect on the overall accuracy of the detector.

Calibration intervals are completely site and local regulations dependant, this will vary widely between different countries, states and sites safety regulations for fixed gas detection systems. The type of sensor will also have an effect on the calibration intervals. An industry recommendation on calibration interval is 4 times a year. The D-Guard™ design has been made to extend the calibration intervals by monitoring and adjusting the sensor outputs. We recommend following regulatory guidelines over manufacture recommendations when regulatory guidelines recommend shorter intervals. Manufactures recommendation on the D-Guard™ for calibration is twice a year with only extending to once a year on low risk gases. Shorter intervals might be recommended depending on selected sensor.

⊗ WARNING: The gas detection equipment is a safety system designed to protect your life and the plant operations. Not calibrating or extending the calibration intervals to save costs, could have a detrimental effect on the accuracy of the system as sensors might not respond.



If the splash guard is fitted this will need to be removed so you can apply the gas directly to the sensor. Remove the splash guard by removing the two screws (4mm Alan key).



The calibration procedure is dependent on whether the sensor is a:

1. Oxygen sensor
2. Toxic sensor (all non-oxygen sensors)

Skip to the appropriate section below depending on the sensor installed in your D-Guard™ unit.

3.3.2.1 Calibrating An Oxygen Sensor

1. Open the calibration plate and the zero calibration menu will be shown, as this setting needs to be adjusted first.

📄 Note: Opening the calibration plate will lock the output signal to the mA equivalent of fresh air 20.9% vol O₂. This will prevent any alarms being generated when calibrating the D-Guard™.

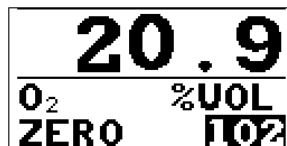

2. When adjusting the zero for an oxygen sensor, a calibration gas must be applied. A calibration plug (Part Number: 81-1125) will be required to apply the calibration gas directly to the sensor.



3. Press the calibration plug into the socket and connect the calibration gas to one of the pipes.



4. Apply the gas at a flow rate of 500cc to 1000cc per minute (1/2Lpm to 1Lpm) to the sensor using the calibration. The gas must be applied for the correct amount of time for the sensor to stabilise, (dependant on the sensor). The nominal time for the sensor to get to stabilise is around 60 seconds. This will vary depending on sensor. If unknown apply gas for 120 seconds.
5. Use the “Up” and “Down” buttons to adjust the reading to the calibration gas value. This is normally “0.0%” when using pure nitrogen or “18.0%” when using a 4 gas mixture containing 18.0% O₂.

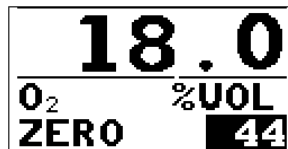

6. You can also press both the “Up” and “Down” buttons together to activate an automatic zero adjustment. Press the “Select” button to move to the next menu.

 **Note: The highlighted zero value, indicates the relative position of the zero adjustment where 0 is the minimum and 255 is the maximum.**

7. The next calibration menu is span. When adjusting the span for an oxygen sensor, the calibration gas must be removed.

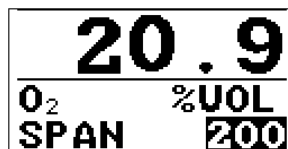

8. Adjust the reading with the “Up” and “Down” buttons until the correct reading is achieved.

9. You can also press both the “Up” and “Down” buttons together to activate an automatic span adjustment. This will adjust the span to 20.9%. Press the “Select” button to move to the next menu.

 **Note:** The highlighted span value, indicates the relative position of the span adjustment where 0 is the minimum and 255 is the maximum.

10. Close the calibration door and re-attach the splash guard. The system is now ready for operation.

 **Note:** The calibration door must be closed before the D-Guard™ will go back into operation. If the door is left open and no buttons pressed for 30 minutes the D-Guard™ will default back into normal operation mode but the IP66/67 rating will drop to IP32 (water and dust can get in damaging the electronics which will void the warranty)

3.3.2.2 Calibrating A Toxic Sensor

1. Open the calibration plate and the zero calibration menu will be shown, as this setting needs to be adjusted first.

 **Note:** Opening the calibration plate will lock the mA output signal at 4mA (zero). This will prevent any alarms being generated when calibrating the D-Guard™.

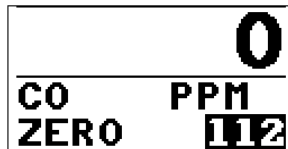

2. With the sensor in a clean gas free environment (no target gas present) you can use the “Up” or “Down” button to adjust the gas reading to “0”.
3. If the area is not clear from the target gas you must use a zero gas calibration gas to remove all the target gas from the sensor.

 **Note:** The highlighted zero value, indicates the relative position of the zero adjustment where 0 is the minimum and 255 is the maximum.

4. You can also press both the “Up” and “Down” buttons together to activate an automatic zero adjustment. Press the “Select” button to move to the next menu.
5. The next calibration menu is for span. When adjusting the span for a toxic sensor, a calibration gas must be applied.

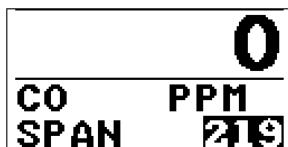

6. A calibration plug (Part Number: 81-1125) will be required to apply the calibration gas directly to the sensor.



7. Press the calibration plug into the socket and connect the calibration gas to one of the pipes.



8. Apply the gas at a flow rate of 500cc to 1000cc per minute (1/2Lpm to 1Lpm) to the sensor using the calibration plug. The gas must be applied for the correct amount of time for the sensor to stabilise, (dependant on the sensor). The nominal time for the sensor to stabilise is around 60 seconds. This will vary depending on sensor. If unknown apply gas for 120 seconds.
9. Adjust the reading with the “Up” or “Down” button until the correct reading is achieved. The correct reading is the calibration gas value.

 **Note: The highlighted span value, indicates the relative position of the span adjustment where 0 is the minimum and 255 is the maximum.**

10. Once the calibration is completed remove the gas and allow the sensor to come back to Zero (or below the low alarm level) before closing the calibration door. Closing the calibration door before the sensor has returned to Zero will release the mA signal and could cause an alarm condition.
11. Close the calibration door and re-attach the splash guard. The system is now ready for operation.

 **Note: the calibration door must be closed before the D-Guard™ will go back into operation. If the door is left open and no buttons pressed for 30 minutes the D-Guard™ will default back into normal operation mode but the IP66/67 rating will drop to IP32 (water and dust can get in damaging the electronics which will void the warranty)**

APPENDIX I. Troubleshooting

Fault	Remedy
Fail to power up	<ol style="list-style-type: none">1. Check power is stable 24VDC2. Reset power supply
Display blank:	<ol style="list-style-type: none">1. Check voltage at the D-Guard™ end. Voltage must be at least 10VDC before the D-Guard™ will power up. If Voltage is correct restart the start up procedure
Sensor fail	<ol style="list-style-type: none">1. Check the Gain setting as the incorrect gain setting can have a sensor fail single before the end of the life of the sensor2. If you get the following message on the screen "SENSORFAIL". This is due to the sensor signal is too weak or too strong.3. Replace sensor
Sensor unstable readings	<ol style="list-style-type: none">1. Check gain setting on sensor as a too high gain setting can result in unstable reading.2. Replace sensor

APPENDIX II. Factory Setup

 **Note:** Before proceeding with any steps in this section, isolate the sensor back at the controller so the D-Guard™ unit will not trip or create any alarms.

Calibrating Zero/Full Loop Current

1. With the D-Guard™ unit powered on, unscrew the calibration plate to access the buttons underneath.



2. Place a jumper cable between pins 1 and 2 on the 10-way IDC header.

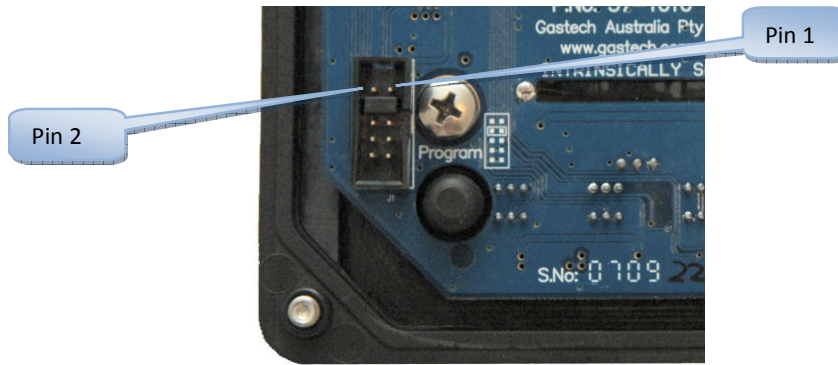

3. Whilst the zero calibration menu is shown, press and hold down the “Select” button for 3 seconds.

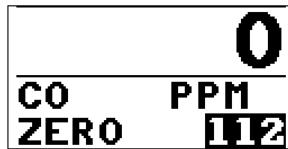

4. You have now entered the factory set up mode. The first screen shows the “Set4ma” setting. This is the zero point loop current calibration menu, where the 4mA value is precisely calibrated.

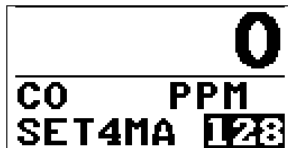

5. The 4mA current loop can be easily measured using a multimeter on millivolts setting across test points TP1 and TP2 shown below. This allows the output to be calibrated without disconnecting the D-Guard™ from the loop.

 **Note:** These two test points have a 10Ω resistor between them, so measuring the voltage across these points, divided by 10 will give the current draw of the unit.

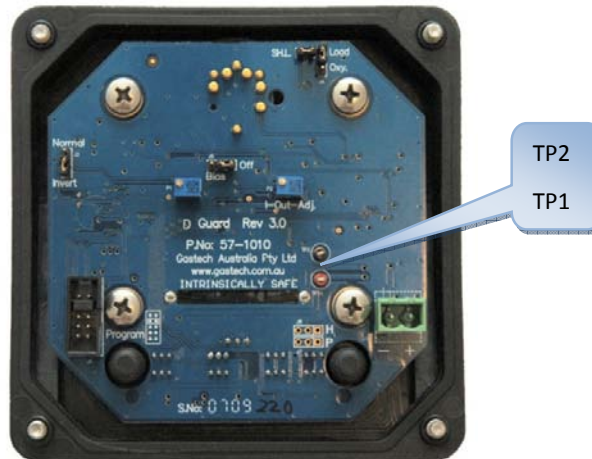

6. Press the “Up” or “Down” buttons until the multimeter reads 40.00mV. This means that the unit is correctly set to 4.000mA at the zero point.
7. Press the “Select” button to move to the next menu.

- This next menu is used to precisely calibrate the full scale loop current to 20mA via a trimpot on the back of the unit.

500	
CO	PPM
SET20MA	TP

- Adjust the trimpot shown below until the reading on the multimeter shows exactly 200.000mV. This means that the unit is correctly set to 20.00mA at the full scale point.

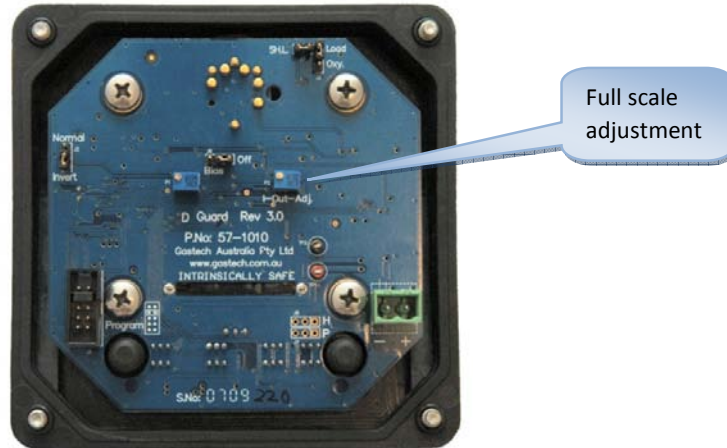

- Once any adjustments have been made, remove the jumper between pins 1 and 2, screw the lid back together, close the calibration door and normal operation will resume.

APPENDIX III. Spare Parts List

A variety of spare parts are available for the D-Guard™ unit.

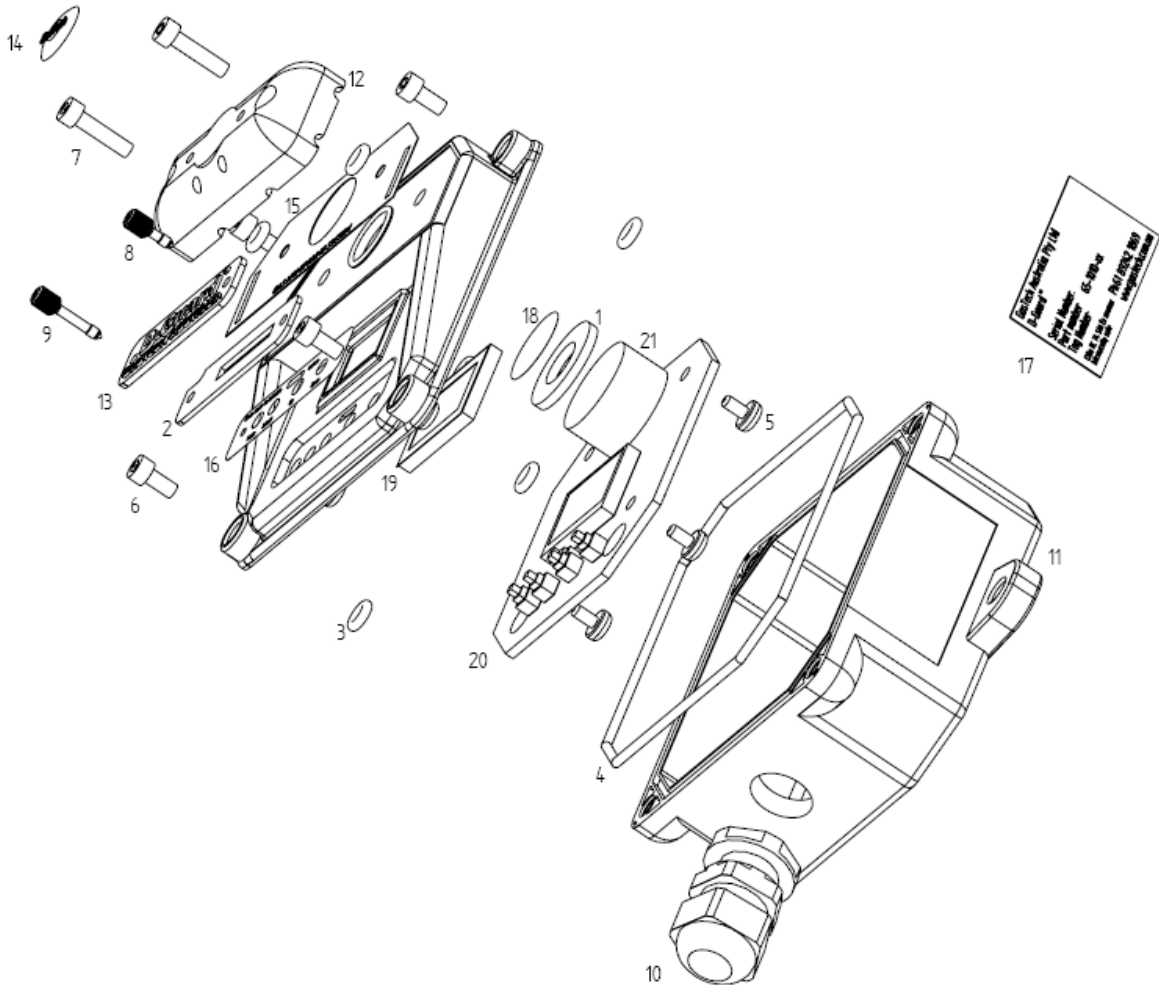

Number	Qty	Part Number	Description
1	1	07-1010-01	Gasket, Sensor, D-Guard™
2	1	07-1010-02	Gasket, Calibration, D-Guard™
3	6	07-1010-10	O-Ring, Cover Screw, D-Guard™
4	1	07-1010-20	O-Ring, Main Housing Seal, D-Guard™
5	4	10-1010-01	Screw, PCB Attachment, D-Guard™ (M5 x 8 Pan Phillips Head, 304 Stainless Steel)
6	4	10-1010-02	Screw, Top Cover, D-Guard™ (M5 x 12 Soc. Hd. Cap, 316 Stainless Steel)
7	2	10-1010-03	Screw, Splash Guard, D-Guard™ (M5 x 20 Soc. Hd. Cap, 316 Stainless Steel)
8	1	10-1010-04	Screw, Captive Panel (Thumbscrew), Cal. Plate, D-Guard™, 10mm Long, Stainless Steel
9	1	10-1010-05	Screw, Captive Panel (Thumbscrew), Cal. Plate, D-Guard™, 17.5mm Long, Stainless Steel
10	1	18-7000	Cable Gland non EXD (65 S and D-Guard™)
11	1	21-1010	Housing (Top and Bottom), D-Guard™
12	1	21-1010-01	Splash Guard, D-Guard™
13	1	21-1010-02	Calibration Plate, D-Guard™
14	1	29-1010-01	Decal, Flexidome, D-Guard™
15	1	29-1010-02	Decal, Top, D-Guard™
16	1	29-1010-03	Decal, Calibration, D-Guard™
17	1	29-1010-04	Nameplate, Serial Number, D-Guard™
18	1	33-9998	Filter 25mm Polypropylene Disc each
19	1	51-1010-01	Window, Polycarbonate, D-Guard™
20	1	57-1010	PCB, Fully Populated, D-Guard™
	1	65-1010-xxx	D-Guard™ intelligent toxic detector (specify gas -xxx)
	1	81-1125	Cal Plug D-Guard™

APPENDIX IV. Specifications

 **Note:** Specifications subject to change without any notice.

Feature	Description
Range	Adjustable to 0-9999.
Gases	Ammonia (NH ₃), Carbon Monoxide (CO), Chlorine (Cl ₂), Hydrogen (H ₂), Hydrogen Cyanide (HCN), Hydrogen Sulphide (H ₂ S), Hydrogen Chloride (HCL), Nitric Oxide (NO), Nitrogen Dioxide (NO ₂), Phosphine (PH ₃), Sulphur Dioxide (SO ₂), Ethylene Oxide (ETO), Oxygen (O ₂), Ozone (O ₃)
Response time	Dependant on sensor installed typical response time is T90 in 10 seconds for oxygen sensor T90 in 30 seconds most other gases.
Repeatability	Sensor dependant typical is 1% of full range
Accuracy	Sensor dependant typical is 1% of full range
Signal	4 to 20 mA
Voltage input	24 VDC nominal (10-30 VDC)
Calibration	mA signal is locked at 4mA when calibration door is open, exception is for oxygen sensor where the mA is locked at 20.9% mA equivalent (depends on range of the O ₂ sensor). 30 minutes time out if door is not closed after calibration or no inputs are seen for 30 minutes. If longer is needed use the isolate switch.
Isolate	Isolate switch will isolate the output to 3mA until the switch is reactivated
Operating temperature	-20° to +55°C
Operating humidity	0 to 95% RH non-condensing
Dimensions	160mm x 273 x 92mm Including standard cable gland and mounting lugs and splashguard.
Weight	Approximately 500g with cable gland and splashguard
Intrinsically safe rating	IEC EX ia IIC T4 TSA 07.0003X

 **Note:** The following specifications apply only to the optional D-Guard™ relay board only.

Feature	Description
Relay outputs	Low alarm relay, high alarm relay, and fault. Programmable for latching/non-latching, 5A/48V max
Low alarm AL1	Independently adjustable from below zero to above full scale. For Oxygen monitors AL1 is programmed to activate when the Oxygen concentration drops below the AL1 setting. For all other types of gases AL1 activates when the concentration rises above the AL1 setting. Visual indication
High alarm AL2	Independently adjustable from below zero to above full scale. AL2 is programmed to activate when the gas concentration rises above the AL2 setting. Visual indication
Fault alarm	Channel fault

APPENDIX V. IECEx Certificate



IECEX Certificate of Conformity

INTERNATIONAL ELECTROTECHNICAL COMMISSION IEC Certification Scheme for Explosive Atmospheres

for rules and details of the IECEx Scheme visit www.iecex.com

Certificate No.: IECEx TSA 07.0003X Issue No.:1 Certificate history: Issue No. 1 (2009-1-28) Issue No. 0 (2007-8-6)

Status: Current

Date of Issue: 2009-01-28 Page 1 of 5

Applicant: GasTech Australia Pty Ltd 106 West Point Center 396 Scarborough Beach Road Osborne Park WA 6017 Australia

Electrical Apparatus: D-Guard Gas Detector Optional accessory:

Type of Protection: Ex ia IIC T4 (Ta=55 degree C) IP66

Marking: GasTech Australia Pty Ltd D-Guard Gas Detector IECEx TSA 07.0003X Ex ia IIC T4 (Ta=55 degree C) IP66 Ui=30V, li=95mA, li(cont)=86.8mA, Pi=0.7W, Ci=36.3nF, Li=Negligible Serial no.

Approved for issue on behalf of the IECEx Certification Body: Ujen Singh Position: Quality & Certification Manager

- 1. This certificate and schedule may only be reproduced in full. 2. This certificate is not transferable and remains the property of the issuing body. 3. The Status and authenticity of this certificate may be verified by visiting the Official IECEx Website.

Certificate issued by:

TestSafe Australia 919 Londonderry Road Londonderry NSW 2753 Australia





IECEx Certificate of Conformity

Certificate No.: IECEx TSA 07.0003X

Date of Issue: 2009-01-28

Issue No.: 1

Page 2 of 5

Manufacturer:

GasTech Australia Pty Ltd
106 West Point Center
396 Scarborough Beach Road
Osborne Park
WA 6017
Australia

Manufacturing location(s):

This certificate is issued as verification that a sample(s), representative of production, was assessed and tested and found to comply with the IEC Standard list below and that the manufacturer's quality system, relating to the Ex products covered by this certificate, was assessed and found to comply with the IECEx Quality system requirements. This certificate is granted subject to the conditions as set out in IECEx Scheme Rules, IECEx 02 and Operational Documents as amended.

STANDARDS:

The electrical apparatus and any acceptable variations to it specified in the schedule of this certificate and the identified documents, was found to comply with the following standards:

IEC 60079-0 : 2004 Edition: 4.0	Electrical apparatus for explosive gas atmospheres - Part 0: General requirements
IEC 60079-11 : 1999 Edition: 4	Electrical apparatus for explosive gas atmospheres - Part 11: Intrinsic safety 'i'

*This Certificate **does not** indicate compliance with electrical safety and performance requirements other than those expressly included in the Standards listed above.*

TEST & ASSESSMENT REPORTS: A sample(s) of the equipment listed has successfully met the examination and test requirements as recorded in

Test Report:

[AU/TSA/ExTR07.0002/00](#)

[AU/TSA/ExTR08.0073/00](#)

Quality Assessment Report:

[AU/TSA/QAR07.0005/00](#)



IECEX Certificate of Conformity

Certificate No.: IECEx TSA 07.0003X

Date of Issue: 2009-01-28

Issue No.: 1

Page 3 of 5

Schedule

EQUIPMENT:

Equipment and systems covered by this certificate are as follows:

The D-Guard Gas Detector is a toxic and oxygen gas detector with graphic LCD display and using the industry standard 24V 4-20mA 2-wire interface. It is to be installed behind an intrinsic safety barrier. It uses the 4-series and the 7-series range of toxic and oxygen electro-chemical sensors.

CONDITIONS OF CERTIFICATION: YES as shown below:

Refer to the Conditions of Certification in attached Annexe for IECEx TSA 07.0003X



IECEX Certificate of Conformity

Certificate No.: IECEx TSA 07.0003X

Date of Issue: 2009-01-28

Issue No.: 1

Page 4 of 5

DETAILS OF CERTIFICATE CHANGES (for issues 1 and above):

Refer to attached Annex for IECEx TSA 08.0073X for details of certificate changes



IECEX Certificate of Conformity

Certificate No.: IECEx TSA 07.0003X

Date of Issue: 2009-01-28

Issue No.: 1

Page 5 of 5

Additional information:

Refer to List of Drawings in attached Annexe for IECEx TSA 07.0003X

Annexe: [Annex for IECEx TSA_07.0003X.pdf](#)