

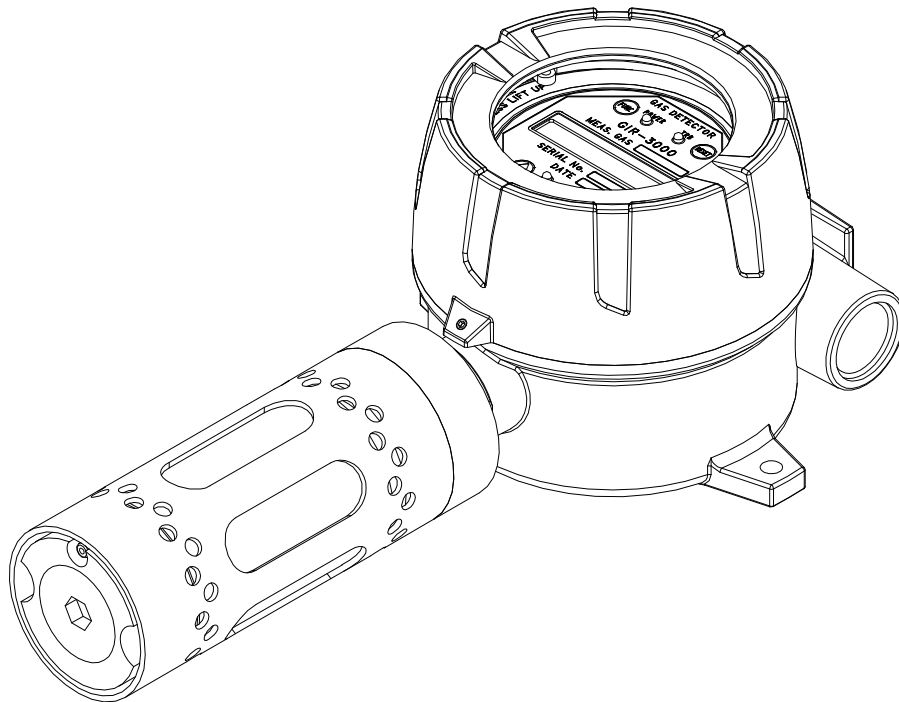

INSTRUCTION MANUAL

MODEL : GIR-3000 **Hydrocarbon Detector**



For proper use, please read this manual carefully!

We much appreciate your wise purchase of GasTech products

At GasTech we strive to manufacture some of the world's most advanced, yet simple to use Gas Detection Systems. These systems are designed to operate in some of the harshest conditions, but still allow the operator to use the detectors with minimal amount of training and/or user input. Safety in hazardous environments is our aim.

The following operating manual serves to explain an installation method, an operating method, a simple maintenance method and other useful guidelines regarding the flammable gas leakage detector "GIR-3000". We trust that this manual will be of good use whenever there are any questions or inquiries during usage of the detector. You are encouraged to carefully read and make good use of the operating manual by safekeeping and referring to the same at your every need.

As always, we once again appreciate your patronage of our products and should you have any inconveniences or problems on our products, kindly contact us at the following address during use to receive prompt attention and necessary measures.

Declaration of conformity in accordance with EC & ATEX directive

NOTE

- **You are kindly requested to get your gas detector inspected and calibrated at least once within a three-month period using calibration gas according to the type of gas in order to ensure an exact operation of the gas alarm, and to receive a periodic inspection including one or more calibration inspections for each six-month period under the provision of relevant Industrial Safety and Sanitary Act promulgated by the Korea Labor Ministry.**
- **No periodic inspections and calibrations may be a cause of erroneous operation of the gas detector due to aged sensor unit.**
- **The disintegration or disassembly of the gas detector needs a person who has a technical expertise on the gas alarm.**
- **You are kindly invited to call our technical department or write to our e-mail address or web site for inspection and calibration of gas detectors or alarms.**

CONTENTS

1. INTRODUCTION - - - - - 4

2. STRUCTURE - - - - - 4

3. SPECIFICATIONS - - - - - 5

4. PART NAME AND MAIN FUNCTIONS - - - - - 7

5. WIRING DIAGRAM - - - - - 10

6. APPERANCE AND DIMENSION- - - - - 13

7. SUPPLY POWER AND OPERATION - - - - - 14

8. HOW TO SET PROGRAMMABLE MODE - - - - - 17

9. HOW TO SET CALIBRATION MODE - - - - - 18

10. HOW TO SET ALARM MODE - - - - - 21

11. HOW TO SET TEST MODE - - - - - 23

12. HOW TO CHECK IR SENSOR DATA - - - - - 24

13. HOW TO SET MAINTENANCE MODE - - - - - 25

14.TROUBLE SHOTTING -- - - - - 26

15. RS-485 COMMUNICTAIONT - - - - - 27

16. BEFORE INSTALLATION - - - - - 28

1. Introduction

Infrared type gas detector GIR-3000 was developed to prevent unfortunate accidents by detecting combustible and Carbon dioxide gas leakage in hazardous places such as plants, gas storages, and factories during manufacture or use of the gases.

When installed in hazardous area, Infrared type gas detector GIR-3000 will regularly and continuously detect the gas leakage and display the data with integrated LCD and to supply 4-20mA standard output, isolated RS-485 communication signal, and relay contact signal on occurrence of Alarms.

Moreover, for DC 4-20mA standard output, output receiving part can be located up to 1,000 m from sensor part (When using CVVS or CVVSB 1.5sq \uparrow Shield Cable), and RS-485 communication signal can be up to 1,000m (when using cable for RS-485 communication)

2. Structure

The Body of GIR-3000 is made of aluminum alloy, which gives perfect Explosion proof structure to it. (Ex d IIC T6)

This product can be installed in every hazardous area with danger of gas leakage and explosion, and integrated LCD displays current gas leakage level on the spot.

The inner structure is composed of LCD panel part that shows measured values, and PCB having terminal parts for delivering measured value (DC4~20mA), isolated RS-485 communication signal, and Alarms signals to outside.

Outside structure is composed of sensing part for detecting gas leakage and cable inlets (2 ea).

Detector can be calibrated from outside of body with magnet bar, which makes maintenance easier.

3. Specification

3-1. Approvals

Hazardous Area Standards	EN 50014, EN50019, EN50028
Code of protection	Ex d IIC T6 (-20 to 60°C)
IP Rating	IP 65
Application	Combustible gas detector

3-2. Functional

Measuring Range	Combustible : 0~10,000ppm & 0~100% LEL & 0~100% VOL CO ₂ : 10% ~ 100% VOL, CO: 5% ~ 100%
Measuring Method	NDIR Cell
Measuring resolution	1 %LEL
Over range indication	Continuously display gas concentration up to 110 %LEL. Above 110 %LEL, display "OVER" with flickering
Calibration level	User selectable 20 %LEL ~90 %LEL in 1 %LEL increments
Alarm 1 level	User selectable 10 %LEL ~60 %LEL in 1 %LEL increments
Alarm 1 output	SPST Signal of Relay Contact: AC125V/1A User selectable Normal Open, Normal Close (default: Normal Open)
Alarm 2 level	User selectable 10 %LEL ~60 %LEL in 1 %LEL increments
Alarm 2 output	SPST Signal of Relay Contact: AC125V/1A User selectable Normal Open, Normal Close (default: Normal Open)
Fault output	SPST Signal of Relay Contact: AC125V/1A User selectable Normal Open, Normal Close (default: Normal Open)
Analogue output during calibration	3.0mA
MODBUS Baud rate	9600 Baud
MODBUS format	1 stop bits, even parity, 8 data bits
MODBUS node address	User selectable (1-63)
Repeatability, Short term	±3% LEL over 1 hour
Repeatability, Long term	±10% LEL over 3 months
Accuracy	±3% LEL/ Full scale
Response Time	90% of full scale in less than 10 sec

3-3. Mechanical

Dimension	156(W) × 146(H) × 110(D) mm
	156 (W) X 322 (H) X 110(D) mm with GSA920A sensor (Detector)
Weight including Sensor	App 3.0Kg
Cable inlet	1/2" or 3/4" PF, NPT(3/4" PF Standard)

3-4. Environmental

Operating temperature range	-20 ~ 60 °C
-----------------------------	-------------

Storage temperature range	-20 ~ 60 °C
Relative humidity range	5% ~ 99%RH
Operating pressure range	90Kpa /110Kpa
Operating Altitude (max)	1000 m
Non operating Altitude (max)	2000 m
EMC (electromagnetic compatibility)	Comply with EN50270

3-5. Electrical

Supply voltage	18VDC/31VDC
Supply voltage ripple & noise max	1Vpp
Current consumption (typical /max)	150mA/250mA@24VDC
Analog output current range	0-22.0 mA
Gas concentration output current range	4-20 mA
Analog output current ripple & noise max	20uApp
Analog output termination resistance (including total cable resistance)	< 600Ω

3-6. Cross sensitivity

Combustible gases		Calibration gas	Cross sensitivity (% relative to C ₄ H ₁₀)
iso-butane	C ₄ H ₁₀	I-C4H10 50% LEL	100
propane	C ₃ H ₈	I-C4H10 50% LEL	110
n-pentane	C ₅ H ₁₂	I-C4H10 50% LEL	105
Methane	CH ₄	I-C4H10 50% LEL	5
n-Hexane	C ₆ H ₁₄	I-C4H10 50% LEL	70
n-Heptane	C ₇ H ₁₆	I-C4H10 50% LEL	65
Methanol	CH ₃ OH	I-C4H10 50% LEL	125
Ethanol	C ₂ H ₅ OH	I-C4H10 50% LEL	90
IPA	C ₃ H ₇ OH	I-C4H10 50% LEL	55
Ethyl acetate	CH ₃ CO ₂ C ₂ H ₅	I-C4H10 50% LEL	22

Combustible gases		Calibration gas	Cross sensitivity (% relative to CH ₄)
Methane	CH ₄	CH ₄ 50% LEL	100
Ethylene	C ₂ H ₄	CH ₄ 50% LEL	40
Acetone	(CH ₃) ₂ CO	CH ₄ 50% LEL	70

* Please inquire to Gastech for other gases

** Even if GIR-3000 is installed in where all kinds of chemicals may leak, its sensitivity would not be reduced

4. Parts Name and Main Functions

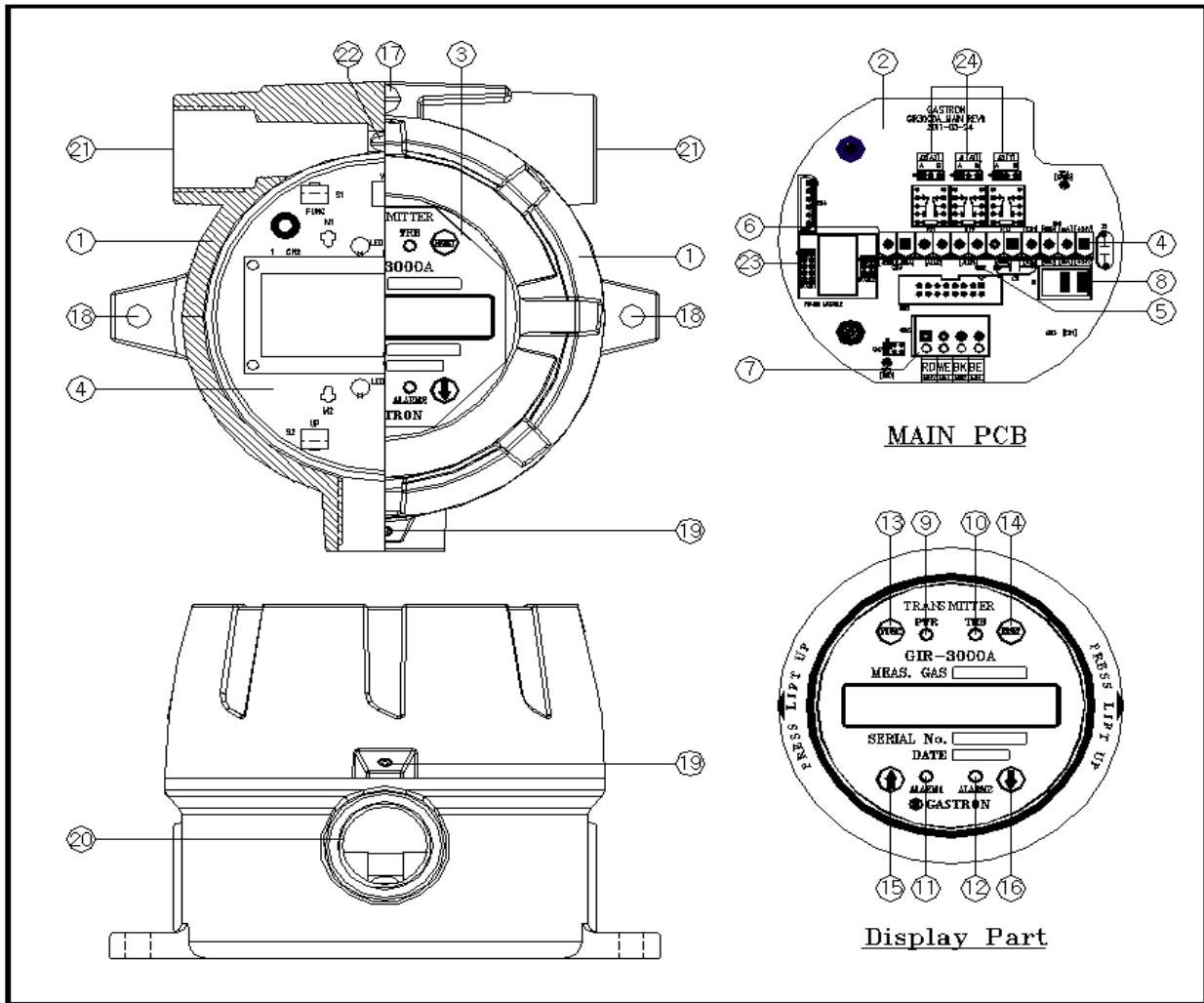

1. HOUSING	13. FUNCTION SWITCH
2. MAIN PCB	14. RESET SWITCH
3. DISPLAY PCB	15. ↑ SWITCH
4. POWER/mA SIGNAL TERMINAL	16. ↓ SWITCH
5. ALARM SIGNAL TERMINAL	17. EXTERNAL EARTH (4sq ↑)
6. RS-485 SIGNAL TERMINAL	18. MOUNT HOLES (2-Ø7)
7. SENSOR TERMINAL	19. COVER FIXED SCREW
8. POWER SWITCH	20. SENSOR THREAD
9. POWER LED LAMP	21. CABLE INLET
10. TROUBLE LED LAMP	22. INTERNAL EARTH (2sq ↑)
11. ALARM1 LED LAMP	23. RS-485 Module (Option)
12. ALARM2 LED LAMP	24. Relay Contact Type Selection

4-1. Housing

Protect sensor and inside PCB board from environmental variation and shocks

4-2. MAIN PCB

To amplify tiny signal from sensor and, to transmit DC 4-20mA signal. Also isolated RS-485 communication signal & Alarm relay contact signals are outputted. It sends signal data to LCD display.

4-3. Display PCB

To display signal data from MAIN (Transmitter) PCB and to indicate current event status with lamps (Power, Alarm and Trouble)

4-4. Power/mA Terminal

CN1 is composed of connection terminal for inputting DC 21-27V power and 4-20mA signal output connection terminal (+, mA, -, ET).

4-5. Alarm signal Terminal

CN2 is Alarm signal connection Terminal, outputting relay contacts (Trouble, Alarm1, and Alarm2)

4-6. RS-485 signal Terminal

CN3 is isolated RS-485 communication signal connection Terminal (A, B)

4-7. Sensor Terminal

CN6 is Sensor connection Terminal.

4-8. Power on/off switch

Please make sure to turn off power switch when doing Cable connection or A/S, and turn on the power switch after completion of work.

4-9. Power lamp

If power switch turns on, lamp will be lit.

4-10. Trouble lamp

This lamp will turn on when the trouble of circuits or sensor sensitivity happens.

4-11. Alarm1 lamp

This lamp turns on when measured value is above Alarm1 level on leakage of gas

4-12. Alarm2 lamp

This lamp turns on when measured value is above Alarm2 level on leakage of gas

4-13. Function switch

When setting parameter, this switch will lead the detector to program mode by touching with magnet bar for over 2 seconds. (Program mode, Calibration mode, Test mode)

Also, any data may be inputted for setting.

4-14. Reset switch

In order to go back to previous mode or cancel current action during parameter setting, touch the switch with magnet bar once. (Every touch will make the detector to go to previous mode)

4-15. (↑) Up switch

When changing the mode or number, touch the switch with magnet bar once and the mode will change to next stage or the number will be increased.

4-16. (↓)Down switch

When changing the mode or number, touch the switch with magnet bar once and the mode will change to previous stage or the number will be decreased.

4-17. External earth

This grounding terminal protects detector from external noises or high voltage.

4-18. Mount Hole (ø7×2ea)

These holes are used to fix the detector to wall and other places.

4-19. Cover Fixed Screw (M4)

This screw is used for fixing Detector Housing Body and Sensor Head to prevent separation from external shock after assembling them.

4-20. Sensor Thread

This is for plugging IR gas sensor.

4-21. Cable inlet

For power supply and in & outputting measuring data. Two types of cable inlets (PF3/4" and PF1/2") are available, and cable inlets (PF3/4") is our standard.

4-22. Internal earth

Grounding terminal of the inside which protects the detector from external noises or high electric field

4-23. RS-485 Module (Optional item)

Isolation Type RS-485 communication Module to communicate with PC or PLC. To connect RS-485 communication It should be given communication address. The default address is 1.

4-24. Relay Contact Type Selection

It is configured to select A or B.

If A is jumper it is operated A relay contact (Normal Open). If B is jumper it is operated B relay contact (Normal Closed).

5. Wiring Diagram

5-1. Separation of Detector Body and Cover

Turn hexagonal socket set screw (M4 * 1ea) from the cover of detector with hexagonal wrench (M2) for 3 or 4 turns counter clock wisely, and turn the cover counter clock-wisely to remove from body. LCD will appear after removal of cover.

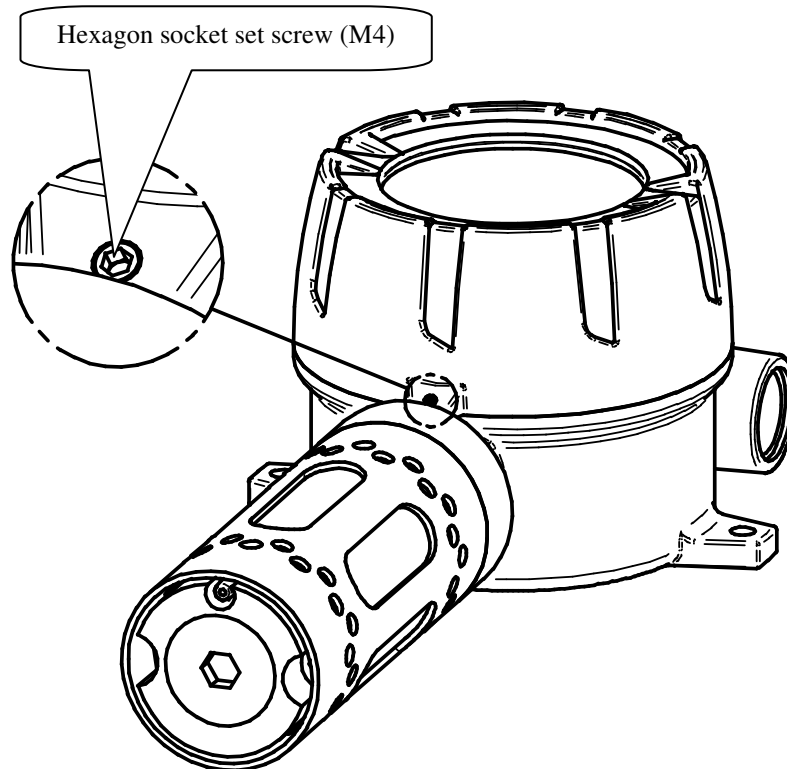

* Caution *

Opening cover or operation of GIR-3000 Detector is prohibited except permitted person or a person in charge for repair in our company. Otherwise, it is possible to suffer for loss of lives and calamity caused by the fire or explosion accident.

Also, please do work after shut off the power certainly and check whether combustible gas and inflammables is remaining around.

5-2. Separation of Display Parts

Press fixing hooks (upper and lower on display parts) simultaneously and pull the display parts up to separate from gas detector body.

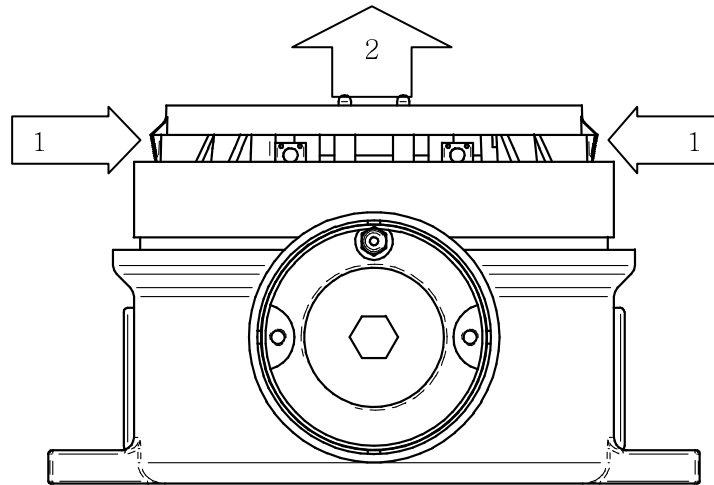

5-3. Connection of power and signal cable

After disassembling Display Parts, Terminal block on Amp/Terminal PCB will be shown. (please refer to below drawing) Pull up this terminal to be disconnected from AMP PCB. Connect DC 24V power supply to +, - of CN1 (+, mA, -, ET) terminal block and signal cable to mA terminal. And insert this terminal block to AMP PCB.

Caution) Please use CVVS or CVVSB 1.5sq \uparrow Shield Cable only.

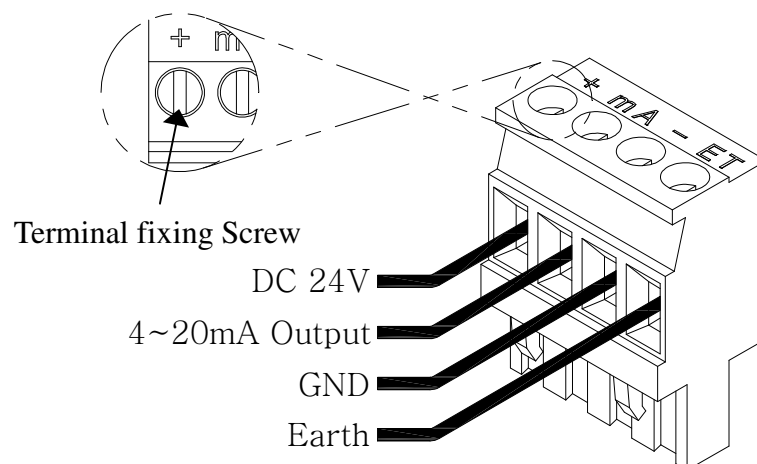

5-3-1. Connecting to GTC-100A, GTC-200A Control Unit

Connect CN1 (+, mA, -, ET) connection terminal of GIR-3200 Gas Detector with 9th (+), 10th (mA), and 11th (-) terminal of GTC-100A Channel Card or 15th (+), 16th (mA), and 17th (-) terminal of GTC-200A channel card.

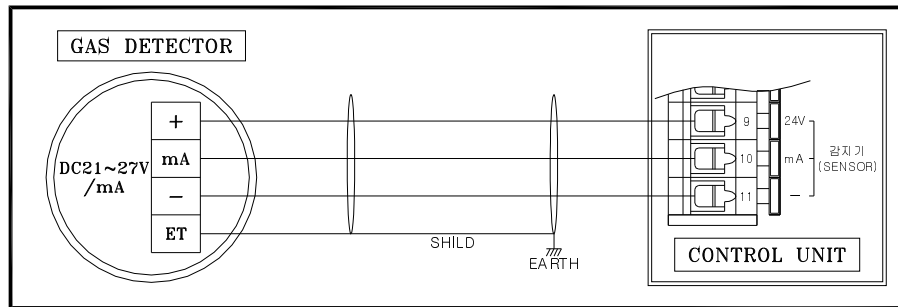

(GTC-100A Control unit)

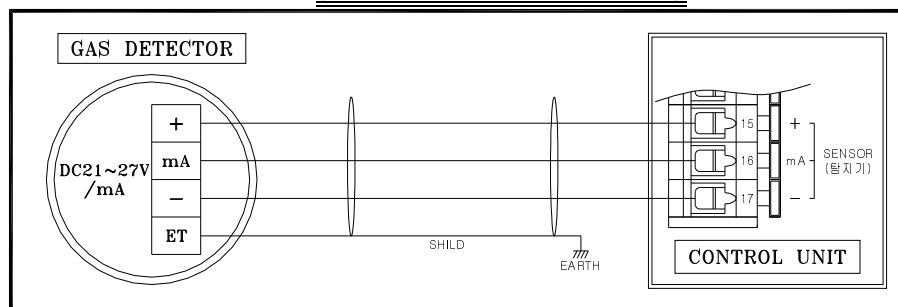

(GTC-200A/210A Series Control unit)

5-3-2. Connecting to other external power source

Connect 18V~31V DC source to CN1 (+, mA, -, ET) connection terminal of GIR-3000 Gas Detector.

Connect signal-detecting application to mA, connection terminal for 4-20mA signal output.

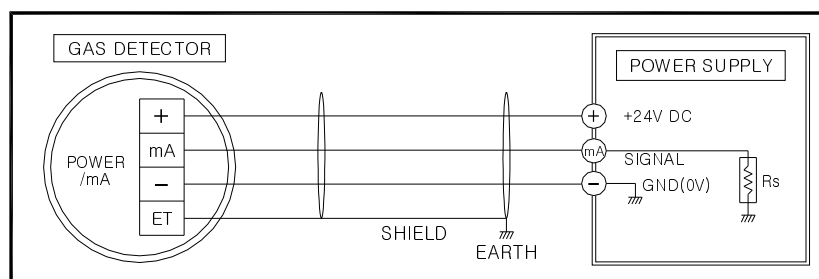

6. Appearance and Dimensions

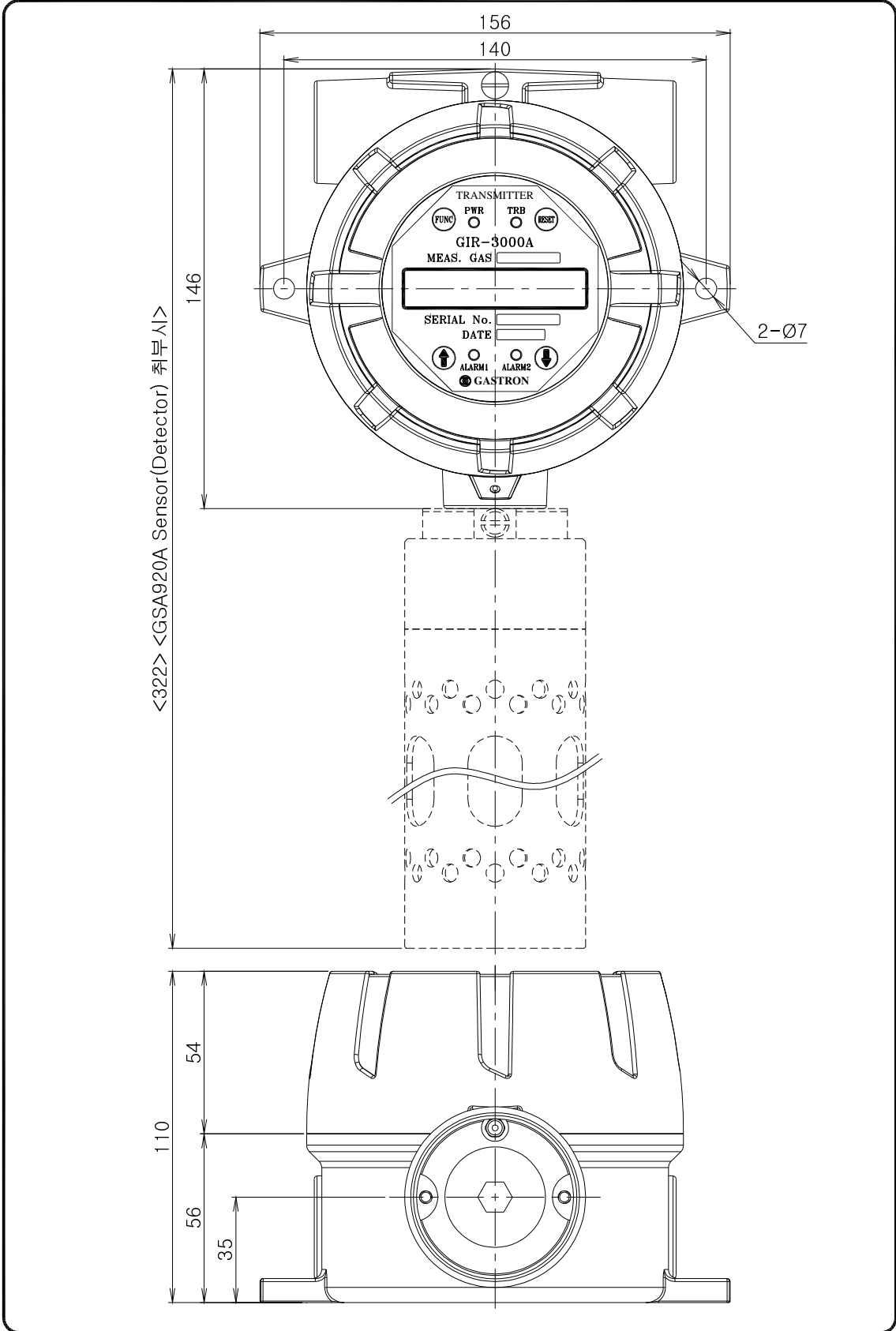

7. Supply Power and Operation

7-1. Connection of power and signal cable

When DC18-31V power is supplied to CN1 Terminal (+), (-) on MAIN PCB board the operation LED is on and “SELF TEST” is displayed on LCD. It takes 30 minutes for being stable and operation normal after supplying initial power to Gas detector.

- Initial Display after Supplying Power

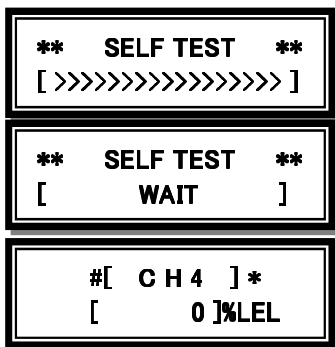

- “SELF TEST[>>>>>]” operating for 1 minute.
- “SELF TEST[WAIT]” keeps for 4 minutes and goes to detection condition.
- Display Gas name in the first raw.
- Display detecting value and detection range in the second raw.
- “#” indicates normal operation condition between Sensor (GSA-920A) and data communication.
- ‘*’ is not displayed in the normal operation but RS-485

7-2. Check Gas Detector Supply Power

- After connecting between CN1 Terminal (mA), (-) and multi-meter(DC) and being stable the detector check LCD display and signal output.
- When gas concentration range displays 0 4mA output is generated. When gas concentration range is full scale output is generated 20mA.
- It is possible to use RS-485 communication signal with Modbus protocol communication to configure PC monitoring system
- Trouble and Gas alarm output signal are generated as relay contact.

7-3. Program Display Menu Tree

Level1	Level2	Level3	Level4	Default	
P A S S W O R D C H E C K	PROGRAMMABLE MODE	GROUP OF GAS SEL	HC/PROPANE/CO/CO2	HC	
		HC	CH4, C2H4, LNG, HC	CH4	
		PROPANE	C3H8, C5H12, C4H10, LPG, H_G		
		CO	CO		
		CO2	CO2		
		UNIT & TAG SEL.	%/%LEL/PPM/PPB	%LEL	
		DECIMAL POINT	0.100/1.00/10.0/100	100	
		HIGH SCALE ADJ.	1~9999	100	
		PASSWORD SET	[-], 00~99	--	
		ADDRESS NO.	[00], 00~64	00	
	CALIBRATION MODE	CALIBRATION ZERO	ZERO CALIBRATION [NO], YES/NO		[NO]
			ZERO CALIBRATION [0]		
			ZERO PROCESSING [SUCCESS], SUCCESS/FAIL		
			CALIBRATION DATA [0]		
		CALIBRATION SPAN	SPAN CALIBRATION [NO], YES/NO		[NO]
			SPAN GAS VALUE [??], 1~Full scale Adj.		50% of Full scale
			[CH4] SPAN GAS [??]		
			SPAN PROCESSING [SUCCESS], SUCCESS/FAIL		
			CALIBRATION DATA [0]		

Level1	Level2	Level3	Level4	Default
P A S S W O R D	ALARM PROGRAM MODE	ALARM OPERATING	AUTO/MANUAL	AUTO
		ALARM1 TYPE SEL.	INCREASE/ DECREASE	INCREASE
		ALARM1 LEVEL ADJ	Adjust 1~Full scale Adj	20
		ALARM1 DEAD BAND	Adjust less than 20% within Full scale	0
		ALARM2 TYPE SEL.	INCREASE/ DECREASE	INCREASE
		ALARM2 LEVEL ADJ	1~Full scale Adj.	40
		ALARM2 DEAD BAND	Adjust less than 20% within Full scale	0
		ALARM RELAY CTL	[YES], YES/NO	YES
		ALARM TIME SET	[01], 0~60sec Adj	01
	TEST MODE	TROUBLE RELAY	[ON],ON/OFF	OFF
		ALARM RELAY	[ON],ON/OFF	OFF
		OUTPUT SIGNAL	[4mA],4mA / 20mA	4mA
		TESTING	
	IR SENSOR DATA MODE	IR Sensor Data Display		
	S/W VERSION	>GIR-3000A : V1.03 >GSA-920A : V1.06		
	MAINTENANCE MODE	CROSS SENS.ADJ.	[1.0] , 0.1~5.0 Adj	1.0
		ZERO SKIP BAND	[ON] , ON/OFF	ON
		TEMP COMPENSATI.	[ON] , ON/OFF	ON
		AUTO ZERO MODE	[ON] , ON/OFF	ON
		ENGINEERING MOD	[OFF] , ON/OFF	OFF
		SENSOR TYPE	[A], A/B	A

8. How To Set Programmable Mode

If touching reset SW in PROGRAM MODE, detector returns to detecting mode. And detector will be returned to PROGRAM MODE when touching reset switch in each program setting step.

[**PASSWORD**]
[[* *]]

- After touching "FUNC" switch with magnet bar for over 2 seconds, detector will go into PASSWORD MODE.
- Input password (2 digits set by user) with "▲" or "▼" switch and touch "FUNC" switch to go into Menu selection mode
- The menu is changed in turns with every touch of "▲" or "▼"

[PROGRAMMABLE]
[M O D E]

(PROGRAMMABLE -> ALARM PROGRAM -> CALIABRATION -> TEST-> IR SENSOR DATA->S/W VERSION)

- If touching "FUNC" switch when displaying "PROGRAMMABLE MODE', detector will go into Program item.

[GROUP OF GAS SEL]
[H C .]

- This step is to set Gas group and the name is changed with every touch of "▲" or "▼" switch.
- When desired gas group is displayed, touch "FUNC" switch to set gas group and detector go into next program item.

[TYPE OF HC]
[C H 4]

- This step is to set Gas name and the name is changed with every touch of "▲" or "▼" switch.
- When desired gas name is displayed, touch "FUNC" switch to set gas name and detector go into next program item

[UNIT & TAG SEL.]
[% L E L]

- This mode is to set Gas measurement unit and, the unit is changed on every touch of "▲" or "▼" switch.
- If desired Gas measurement unit is displayed, touch "FUNC" switch to set the unit and go to next program item.

[DECIMAL POINT]
[1 0 0 . 0]

- This mode is to set decimal point and, the decimal point is changed on every touch of "▲" or "▼" switch.
- If desired decimal point is displayed, touch "FUNC" switch to set the point and go to next program item.

[HIGH SCALE ADJ.]
[1 0 0 . 0]

- This mode is to set the High scale to be displayed on Full Range and, the scale value is increased or decreased on every touch of "▲" or "▼" switch.
- If desired High scale is displayed, touch "FUNC" switch to set High scale value and go to next program item

[PASSWORD SET]
[[- -]]

- This mode is to set the password, be checked before going into parameter changing mode or Maintenance mode. The password number is increased or decreased on every touch of "▲" or "▼" switch.
- If desired password number is displayed, touch "FUNC" switch to set the password and go to next program item.

[ADDRESS NO.]
[[0 0]]

- This mode is to set the address of each detector for RS-485 MODBUS communication and, the address is increased or decreased on every touch of "▲" or "▼" switch. (Address can be selected from 1 to 64 and the address shall not be duplicated. This step can be omitted when not using RS-485 communication)

-If desired address number is displayed, touch "FUNC" switch to set the address and go to next program item.

9. How To Set Calibration Mode

Gas detector requires at least 30 minutes of first stabilization time after supplying power due to characteristics of the sensor. However, management requirements may be changed according to onsite condition.

9-1. Zero Calibration

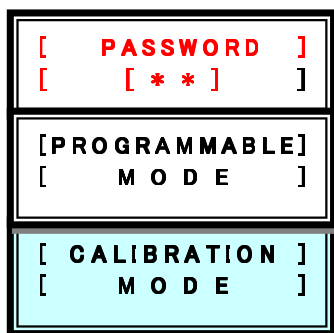

- After touching "FUNC" switch with magnet bar for over 2 seconds, detector will go into PASSWORD MODE.
- Input password (2 digit numbers) with "▲" or "▼" switch and touch "FUNC" switch to go into menu selection mode
- Select "CALIBRATION MODE" by touching "▲" or "▼" switch.
- If Calibration mode is displayed, touch "FUNC" switch to go into Calibration items.
- If touching "RESET" switch, detector returns to detection condition.

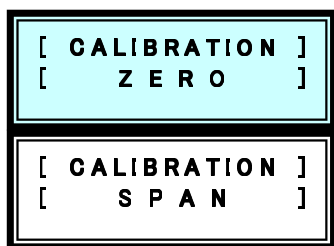

- This mode is to set calibration items, and two items (ZERO, SPAN) are changed in order by touching "▲" or "▼" switch.
- If "CALIBRATION ZERO" is displayed, touch "FUNC" switch to select Zero Calibration item and go into Zero Calibration Mode.
- If touching "RESET" switch, detector returns to "CALIBRATION MODE"

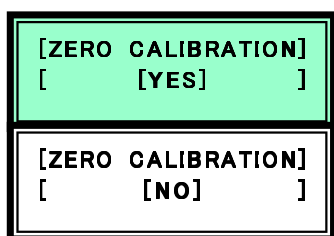

- When displaying [YES] after touching "▲" or "▼" switch, touch "FUNC" switch to go into Zero Calibration Mode.

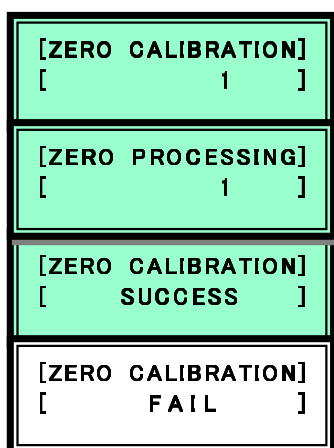

- This mode is to perform Zero Calibration, and measurement value for Zero Calibration is displayed on second line.
- Insert clean air or 100% nitrogen for 1 minute at the rate of 500mL/min with calibrating tool
- Touch "FUNC" switch again when the reading is stabilized and, display will show "ZERO CALIBRATION SUCCESS" for over 2 seconds on the LCD and the detector will go to " CALIBRATION DATA" mode if zero calibration succeeds. If failed, display will show "ZERO CALIBRATION FAIL" for over 2 seconds on the LCD and the detector will go to "CALIBRATION DATA" mode.
- If touching "RESET" switch, detector returns to "CALIBRATION MODE".



- This mode is to display measurement value after calibration and to check if the calibration was normally performed.
- If touching "RESET" switch, detector returns to "CALIBRATION MODE".

9-2. Span Calibration



- After touching "FUNC" switch with magnet bar for over 2 seconds in detecting mode, detector will go into PASSWORD MODE.
- Input password (2 digit numbers) with "▲" or "▼" switch and touch "FUNC" switch to go into Menu selection mode.
- Select "CALIBRATION MODE" by touching "▲" or "▼" switch.
- If Calibration mode is displayed, touch "FUNC" switch to go into Calibration items.
- If touching "RESET" switch, detector returns to detection condition.



- This is to set calibration items, and two items (ZERO, SPAN) are changed in order by touching "▲" or "▼" switch.
- When "CALIBRATION SPAN" is displayed, touch "FUNC" switch to select Span Calibration items and go into SPAN CALIBRATION MODE.
- If touching "RESET" switch, detector returns to "CALIBRATION MODE".

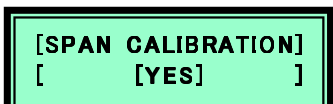

- When displaying [YES] after touching "▲" or "▼" switch, touch "FUNC" switch to go into "SPAN CALIBRATION MODE"



- This mode is to set standard gas value, and touch "▲" or "▼" switch to set the value (1~full scale).

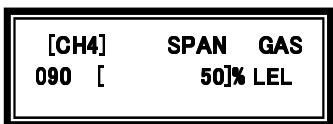

- This mode is to inject standard gas and measurement value is held at maximum value and displayed.
- Insert standard gas for 90second at flow rate of 1000mL/min with calibrating tool. After stabilization of reading, touch "FUNC" switch to automatically do SPAN CALIBRATION..



- If span calibration succeeds, display will show "SPAN GAS VALUE SUCCESS" for 2 seconds and go to



If failed, "SPAN GAS VALUE FAIL" will be shown for 2 seconds and

detector returns to “CALIBRATION DATA” mode.

- . If touching “RESET” switch, detector returns to “CALIBRA. MODE”



- . This mode is to display measurement value after calibration and to check if the calibration was normally performed.

- . If touching “RESET” switch, detector returns to “CALIBRATION MODE”.

10. How To Set Alarm Mode

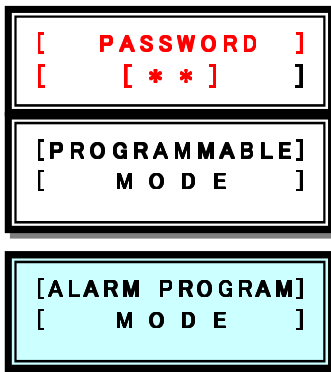

- Touch "FUNC" switch for over 2 seconds with magnetic bar to go into PASSWORD MODE.
- Input password (2 digit numbers) with "▲" or "▼" switch and touch "FUNC" switch to go into PROGRAMMABLE MODE.

- Select "ALARM PROGRAM MODE" by touching "▲" or "▼" switch.
- If alarm program mode is displayed, touch "FUNC" switch to go into alarm program items.
- If touching "RESET" switch, detector returns to detection condition.

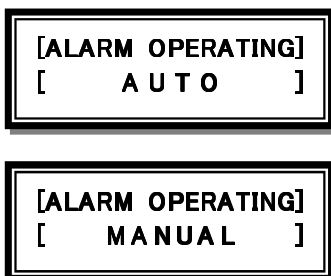

- This mode is to set alarm resetting type, and touch "▲" or "▼" switch for alternately changing between "AUTO" and "MANUAL".
- "AUTO" mode is to reset alarm automatically and "MANUAL" mode is to reset alarm by touching reset switch.
- If desired mode is displayed, touch "FUNC" switch to set and go to next alarm program item.
- For returning to "ALARM PROGRAM MODE", touch "RESET" switch.



- This mode is to set moving direction of Alarm1, and touch "▲" or "▼" switch to display "INCREASE" or "DECREASE".
- "INCREASE" mode is to be activated when the measurement value is same or higher than Alarm setting value, and "DECREASE" Mode is to be activated when the measured value is same or lower than Alarm setting value.
- If desired mode is displayed, touch "FUNC" switch to set mode and go to next Alarm Program items.
- For returning to "ALARM PROGRAM MODE", touch "RESET" switch.



- This mode is to set Alarm1 level, and touch "▲" or "▼" switch to increase or decrease Alarm1 value.
- If desired Alarm1 value is displayed, touch "FUNC" switch to set the value as Alarm1 and go to next Alarm Program items.
- For returning to "ALARM PROGRAM MODE", touch "RESET" switch.



- This mode is to set the activation range of Alarm1 and, touch "▲" or "▼" switch to increase or decrease value.
- In case of "INCREASE" mode, Alarm is activated on the value (Alarm value + Dead band setting value) and is deactivated on the value (Alarm

value – Dead band setting value).

-. If desired value is displayed, touch “FUNC” switch to set Dead band value and go to next Alarm Program items.

-. For returning to “ALARM PROGRAM MODE”, touch “RESET” switch.



-. This mode is to set moving direction of Alarm1, and touch “▲” or “▼” switch to display “INCREASE” or “DECREASE”.

-. “INCREASE” mode is to be activated when the measurement value is same or higher than Alarm setting value, and “DECREASE” Mode is to be activated when the measured value is same or lower than Alarm setting value.

-.If desired mode is displayed, touch “FUNC” switch to set mode and go to next Alarm Program items.

-. For returning to “ALARM PROGRAM MODE”, touch “RESET” switch.



-. This mode is to set Alarm2 level, and touch “▲” or “▼” switch to increase or decrease Alarm2 value.

-. If desired Alarm2 value is displayed, touch “FUNC” switch to set the value as Alarm2 and go to next Alarm Program items.

-. For returning to “ALARM PROGRAM MODE”, touch “RESET” switch.



-. This mode is to set the activation range of Alarm2 and, touch “▲” or “▼” switch to increase or decrease value.

-. In case of “INCREASE” mode, Alarm is activated on the value (Alarm value + Dead band setting value) and is deactivated on the value (Alarm value – Dead band setting value).

-. If desired value is displayed, touch “FUNC” switch to set Dead band value and go to next Alarm Program items.

-. For returning to “ALARM PROGRAM MODE”, touch “RESET” switch.

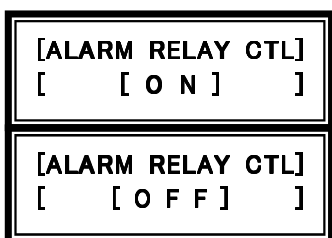

-. This mode is to set relay contact control on Alarm, touch “▲” or “▼” switch to display “ON” or “OFF”.

-. If desired mode is displayed, touch “FUNC” switch to set and go to next Alarm Program item.

-. For returning to “ALARM PROGRAM MODE”, touch “RESET” switch.



-. This mode is to set minimum time to hold measured value in order to activate Alarm, touch “▲” or “▼” switch to increase or decrease value.

-. Displayed value represents second (0~60).

-. If desired value is displayed, touch “FUNC” switch to set the value and go to “ALARM PROGRAM MODE” mode.

-. For returning to “ALARM PROGRAM MODE”, touch “RESET” switch.

11. How To Set Test Mode

[**PASSWORD**]
[[* *]]

[PROGRAMMABLE]
[M O D E]

[T E S T]
[M O D E]

- Touch "FUNC" switch for over 2 seconds with magnetic bar on detecting mode and go to PASSWORD MODE.

- Input password (2 digit numbers) with "▲" or "▼" switch and touch "FUNC" switch to go into Menu selection mode.

- Touch "▲" or "▼" switch to go into "TEST MODE"

- If Test mode is displayed, touch "FUNC" switch to go to Test item mode

[TROUBLE RELAY]
[[O N]]

- This mode is to set Trouble relay Test action (ON or OFF), and touch "▲" or "▼" switch to display "ON" or "OFF"

[TROUBLE RELAY]
[[O F F]]

- If desired mode is displayed, touch "FUNC" switch to set and go to next Test mode item.

- For returning to "TEST MODE", touch "RESET" switch.

[ALARM RELAY]
[[O N]]

- This mode is to set Alarm relay Test action (ON or OFF), and touch "▲" or "▼" switch to display "ON" or "OFF"

[ALARM RELAY]
[[O F F]]

- If desired mode is displayed, touch "FUNC" switch to set and go to next Test mode item

- For returning to "TEST MODE", touch "RESET" switch.

[OUTPUT SIGNAL]
[[4 m A]]

- This mode is to set Output signal Test action (4mA or 20mA), and touch "▲" or "▼" switch to display "4mA" or "20mA"

[OUTPUT SIGNAL]
[[2 0 m A]]

- If desired mode is displayed, touch "FUNC" switch to set and go to next Test mode item.

- For returning to "TEST MODE", touch "RESET" switch.

[T E S T I N G]
[... ..]

- This mode is to test Trouble/Alarm Relays and Output signal with predetermined value

- Test will be stopped on touching any switch among 4 ea and returns to "TEST MODE" menu.

12. How To Check IR Sensor Data

[**PASSWORD**]
[[* *]]

- After touching "FUNC" switch with magnetic bar for over 2 seconds, detector will go into PASSWORD MODE.
- Input password (2 digit numbers) with "▲" or "▼" switch and touch "FUNC" switch to go into Menu selection mode.

[**PROGRAMMABLE**]
[M O D E]

- Select "IR SENSOR DATA MODE" by touching "▲" or "▼" switch
- When IR sensor data mode is displayed, touch "FUNC" switch to go into IR sensor data mode items

[**IR SENSOR DATA**]
[M O D E]

[**M: 0.6000 / 0.6000**]
[**1.350, 1.300, +200**]

- This mode is to display IR sensor data , output voltage Temperature.
(Detector sensor value/ Reference sensor value)
- If touching "FUNC" switch to go into next MODE.

[**Z : 0.6000 / 0.6000**]
[**S : 0.5000 / 0.6000**]

- This mode is to display sensor data after manual ZERO or SPAN calibration.
- If touching "FUNC" switch to go into next MODE.

[**Z : +20℃**]
[**S : +18℃**]

- This mode is to display temperature value after manual ZERO or SPAN calibration.
- If touching "FUNC" switch to go into next MODE.

[**AZ : EN +20℃**]
[**0.5000 / 0.5000**]

- This mode is to display IR sensor data and temperature value after auto ZERO or SPAN calibration.
- If touching "FUNC" switch to go into next MODE.

[**VIN : 23.5V**]
[**MIN:18V MAX:31V**]

- This mode is to display power supply to internal PCB.
- If touching "FUNC" switch to go into next MODE.

13. How To Set Maintenance Mode

Most functions for maintenance were set up at factory. So be careful not to operate these functions at normal condition. In unavoidable case, please perform this step with technical assistance from GasTech.

[PASSWORD]
[* *]

- After touching “▲” or “▼” switch with magnet bar for over 2 seconds in detecting mode, detector will go into PASSWORD MODE.
- Input password (2 digit numbers) with “▲” or “▼” switch and touch “FUNC” switch to go into Maintenance mode.

[PROGRAMMABLE]
[MODE]

[MAINTENANCE]
[MODE]

- This mode is to select Maintenance Item with touching “▲” or “▼” switch.

[CROSS SENS.ADJ]
[1.0 X GAS]

- This is to set sensor cross sensitivity (5.0 ~ 0.1) and touch “▲” or “▼” switch to set the value as increasing 0.1 unit. (default 1.0)

[ZERO SKIP BAND]
[ON]

- This is to set sensor ZERO sensitivity and touch “▲” or “▼” switch to select ON or OFF. If setting ON the sensor measuring value setting is process as following.

★ If the value is 0~2% of high scale setting 0 and if 2~3.3% setting 2% deduction value by force. If the value is 3.3%~100% of high scale keeps the detecting value.

(default ON)

[TEMP COMPENSAT]
[ON]

- This is to set sensor temperature compensation function and touch “▲” or “▼” switch to select ON or OFF. If setting ON it is processed (default ON)

[AUTO ZERO MODE]
[ON]

- This is to set auto zero function and touch “▲” or “▼” switch to select ON or OFF. If setting ON it is processed (default ON)

[ENGINEERING MODE]
[OFF]

- This is to set temperature display and –LEL display function and touch “▲” or “▼” switch to select ON or OFF. If setting ON it is processed (default ON)

NOTE) this mode is activated for only TEST MODE and N/A in a field.

[SENSOR TYPE]
[A]

- This is to set IR sensor type. The default value is A and if the set is changed in a field it is affected to sensor response time. Hence the factory setting is recommended.

14. Trouble Shooting

Code Message	Description & Condition	Recovery
FAULT0 "TSM-MEM C/S"	Self testing Memory(FLASH, RAM) Check Sum inside of GIR3000A transmitter	Transmitter PCB MPU FAULT (U1)
FAULT1 "TSM-EEPROM"	Self testing EEPROM Check Sum or EEPROM operation inside of GIR3000A transmitter	Transmitter PCB EEPROM FAULT (U4)
FAULT2 "SEN-MEM C/S"	Self testing Memory(FLASH, RAM) Check Sum inside of GSA920A sensor	SENSOR (GSA-920A)FAULT
FAULT3 "SEN-EEPROM"	Self testing EEPROM Check Sum or EEPROM operating inside of GSA920A sensor	SENSOR (GSA-920A)FAULT
FAULT4 "SEN-COM T/O"	Self checking communication between GIR3000A transmitter and GSA920A	CN6 sensor terminal wiring or sensor (GSA-920A) FAULT
FAULT5 "SEN-CHANGE(DET)"	Self checking IR detector channel power condition (0.1V range) inside of GSA920A	Check sensor(GSA-920A) filter and wave pipe, gas sensor fail
FAULT6 "SEN-CHANGE(REF)"	Self checking IR reference channel power condition (0.1V range) inside of GSA920A	Check sensor(GSA-920A) filter and wave pipe, gas sensor fail
FAULT7 "SEN-CHANGE(OPT)"	Self checking both of IR detector channel and reference channel power condition (0.1V range) inside of GSA920A	Check sensor(GSA-920A) filter and wave pipe, gas sensor fail
FAULT8	RESERVED	
FAULT9 "SEN-D,RCH LOW"	Self checking both of IR detector channel and reference channel power condition (0.03V range) inside of GSA920A	Check sensor(GSA-920A) filter and wave pipe, gas sensor fail
FAULT10 ">SEN-EMPERATURE"	Self checking operation temperature (+75~ - 40'C) of IR sensor	Ambient temp check, temperature sensor fail
FAULT11 ">SEN-VERSION"	Self checking GSA920A sensor version (0~99) of GIR3000A Transmitter	Sensor(GSA-920A) program fault
FAULT12 ">VIN LOW VOLTAGE"	Self checking GSA920A sensor input power (17V)	Check input power (normal 24V)

15. RS-485 Data Communication

15-1. RS-485 data communication Format

- . Baud rate : 9600BPS
- . Stop bit : 1 Stop
- . Parity : Even parity

15-2. Gas concentration (Analog input)

No	Function name	Address	Other
1	Gas concentration value	30001	
2	High scale setting value	30002	

15-3. Unit status Bit Data (Digital input contact reading Data)

No	Function name	Address	Other
1	Alarm1 status Data	10001	
2	Alarm 2 status Data	10002	
3	Trouble status Data	10003	

16. Before Installation

16-1. Deciding installation site

(Data from Industrial Safety and sanitation law in Korea)

Installation site of gas leakage detector should follow the categories below.

- 1) Place where gas leakage is suspected such as compressor, valve, reactor, piping connections and chemical and corrosive installments used for combustible and/or toxic gases
- 2) Place where gas may dwell and near source of heat such as a heater in factory.
- 3) Connection of chargers for combustible and/or toxic material.
- 4) Transformer rooms, distribution rooms, and control rooms in hazardous area.
- 5) Other places where gas can congregate easily.

16-2. Deciding installation site

(Data from Laws regarding safety management of highly pressurized gas in Korea)

Gas leakage detector should be installed near the places where leakage is suspected. However, if the place has hazard of gas dwelling but does not have direct leakage, the detectors should be installed in following places.

- 1) Gas leakage detectors, which are installed outside a building, should be installed in places where gas may dwell considering direction of wind, speed of wind, and weight of the gas.
- 2) Gas leakage detectors, which are installed inside a building, should be installed near the base of the building if the gas is heavier than air and should be installed near vent or top of the building if the gas is lighter than air. Gas leakage detectors should be installed in working places.

16-3. Cautions on installation

We recommend installing detector where periodic maintenance can be easily performed. Also, please avoid installation where water (rain) may access and where vibrations or shocks may happen. Vibrations or shocks may cause wrong reading.

- ⊙ This gas detector has flame proof structure and can be used in group II, zone 0, zone 1 and zone 2 area
- ⊙ Permissible temperature is below 85 °C (T6)
- ⊙ Ambient temperature is between -20 °C ~ 60 °C

- ⦿ Installation height: Below 1000M above sea level
 - Relative humidity: 0% to 95%
 - Installation place: In/Out door
 - Explosion/ignition proof approval: Ex d IIC T6
- ⦿ In case of using metal conduit or explosion proof cable gland to cable inlet when doing wiring work, please seal the conduit (within 45 cm) not to spread flame or gas through the conduit.
- ⦿ When connecting this detector with conduit, the screw thread should be more than 5 times.
- ⦿ Every material for cable inlet "Cable gland, sealing fitting and etc" should be passed for an authorization certainly!

The products and instruction manual can be revised for improvement performance and easy use without prior notice.



24, Baretta Rd, Wangara, Western Australia 6065.

Telephone: 1800 999 902

Facsimile: 1800 999 903

Int. Phone: +61 8 6108 0000

Int. Fax: +61 8 9408 1868

Email: info@gastech.com.au

Website: <http://www.gastech.com.au>