

# SafEye™

## Series 300

Open-Path Gas Detection System

# User and Maintenance Manual

TM 794100, Rev. D, June 2004



### UL Approved

E209870, Class I Group C and D

### ATEX (Cenelec) Approved

Ex II 2 G, EExd IIB +H<sub>2</sub> T5  
EExde IIB +H<sub>2</sub> T5



GasTech Australia Pty Ltd  
24 Baretta Rd  
Wangara Western Australia 6065  
Tel 1800 999 902  
Fax 1800 999 903  
<http://www.gastech.com.au>



The SafEye monitoring system described in this document is the property of Spectrex, Inc.

No part of the hardware, software or documentation may be reproduced, transmitted, transcribed, stored in a retrieval system, or translated into any language or computer language, in any form or by any means, without prior written permission of Spectrex, Inc.

While great efforts have been made to assure the accuracy and clarity of this document, Spectrex, Inc. assumes no liability resulting from any omissions in this document, or from misuse of the information obtained herein. The information in this document has been carefully checked and is believed to be entirely reliable with all of the necessary information included. Spectrex Inc. reserves the right to make changes to any products described herein to improve reliability, function, or design, and reserves the right to revise this document and make changes from time to time in content hereof with no obligation to notify any persons of revisions or changes. Spectrex, Inc. does not assume any liability arising out of the application or any use of any product or circuit described herein; neither does it convey license under its patent rights or the rights of others.

**Warning:**

This manual should be carefully read by all individuals who have or will have responsibility for using, maintaining or servicing the product.

The Source and Detector are not field-repairable due to the meticulous internal alignment and calibration of the sensors and the respective circuits. Do not attempt to modify or repair the internal circuits or change their settings, as this will impair the system's performance and void the Spectrex Inc. Product warranty.



## TABLE OF CONTENTS

<b>1. Scope .....</b>	<b>1</b>
<b>1.1 Product Overview.....</b>	<b>1</b>
<b>1.2 Document Overview.....</b>	<b>1</b>
<b>2. Technical Description.....</b>	<b>2</b>
<b>2.1 Features.....</b>	<b>2</b>
<b>2.2 Applications .....</b>	<b>2</b>
<b>2.3 Principle of Operation.....</b>	<b>2</b>
2.3.1 Definitions of Terms .....	3
2.3.2 Spectral Finger Print .....	3
2.3.3 Optical Path.....	3
2.3.4 Microprocessor Based.....	3
2.3.5 Gas Sensitivity .....	4
2.3.6 Gas and Mixture Selection and Setting .....	4
<b>2.4 Product Marking.....</b>	<b>5</b>
<b>2.5 Models and Types .....</b>	<b>5</b>
<b>2.6 Description.....</b>	<b>6</b>
2.6.1 Light Source Unit .....	6
2.6.2 Detector Unit (Figure 2).....	7
<b>3. Operation Mode.....</b>	<b>8</b>
<b>3.1 Normal Mode.....</b>	<b>8</b>
<b>3.2 Fault Mode.....</b>	<b>8</b>
<b>3.3 Alignment Mode .....</b>	<b>8</b>
<b>3.4 Zero Calibration Mode (1mA Output) .....</b>	<b>8</b>
<b>3.5 Mode Selection.....</b>	<b>9</b>
<b>3.6 Visual Indications LEDs.....</b>	<b>9</b>
<b>3.7 Output Signals .....</b>	<b>10</b>
3.7.1 4-20mA Current Output .....	10
3.7.2 Relays.....	11
3.7.3 RS-485 Interface .....	11
<b>3.8 Terminals .....</b>	<b>12</b>
3.8.1 Detector Terminal .....	12
3.8.2 Light Source Terminals.....	14
<b>3.9 System Setup.....</b>	<b>15</b>
3.9.1 Detector Setting.....	15
<b>4. Technical Specifications .....</b>	<b>19</b>
<b>4.1 General Specifications .....</b>	<b>19</b>

<b>4.2 Electrical Specifications .....</b>	<b>20</b>
<b>4.3 Mechanical Specifications .....</b>	<b>21</b>
<b>4.4 Environmental Specifications .....</b>	<b>22</b>
<b>5. Installation Instructions .....</b>	<b>23</b>
<b>5.1 Introduction.....</b>	<b>23</b>
<b>5.2 General Considerations .....</b>	<b>23</b>
5.2.1 Personnel.....	23
5.2.2 Tools Required.....	23
5.2.3 Site Requirements .....	23
5.2.4 The Source and Detector.....	23
5.2.5 Guidance Tips for Gas Detector Locations.....	24
<b>5.3 Preparations for Installation.....</b>	<b>24</b>
<b>5.4 Mounting for Standard Open-Path Installation .....</b>	<b>25</b>
5.4.1 Swivel Mount Kit.....	25
5.4.2 Swivel Installation (Figure 6) .....	25
5.4.3 Tilt Mount Kit .....	27
5.4.4 Detector / Source Installation (Figure No. 7 and 8) .....	29
<b>5.5 Mounting for Duct Installation.....</b>	<b>29</b>
5.5.1 Duct Mount Set (Figure 10, 11).....	29
5.5.2 Duct Alignment Set (Figure 12) and Accessories .....	30
5.5.3 Duct Installation - Surface Preparation (Figure 9).....	30
5.5.4.Duct Mount Installation (Figures 10,11) .....	32
5.5.5 Duct Mount Alignment (Figures 11,12) .....	35
<b>5.6 Detector Wiring (see appendix D if EExde version used) .....</b>	<b>37</b>
5.6.1 Conduit/Cable Installation .....	37
5.6.2 Harness Connection (Figure 13) .....	38
5.6.3 Detector Terminal Wiring.....	40
<b>5.7 Light Source Wiring .....</b>	<b>41</b>
5.7.1 Power Supply .....	41
5.7.2 Harness Connection (Figure 13) .....	41
5.7.3 Terminal Wiring (Table 6).....	41
<b>6. Operating Instructions .....</b>	<b>43</b>
<b>6.1 SafEye Operation.....</b>	<b>43</b>
<b>6.2 Alignment of Unit (Figures 15 through 16) Using Swivel Mount.....</b>	<b>43</b>
<b>6.3 Alignment of Unit (Figure 7, 8) Using Tilt Mount .....</b>	<b>46</b>
<b>6.4 Powering on the system.....</b>	<b>47</b>
<b>6.5 Safety Precautions .....</b>	<b>47</b>
<b>6.6 Zero Calibration.....</b>	<b>47</b>
<b>6.7 Functional Check of Unit .....</b>	<b>48</b>

<b>7. Maintenance Instructions.....</b>	<b>49</b>
<b>7.1 General Maintenance.....</b>	<b>49</b>
<b>7.2 Periodic Maintenance.....</b>	<b>49</b>
7.2.1 Routine Optical Surface Cleaning .....	50
7.2.2 Signal Verification .....	50
7.2.3 Function Check of Unit.....	51
7.2.4 Maintenance Records .....	51
<b>8. Troubleshooting.....</b>	<b>52</b>
<b>Appendix A - Wire Selection Tables .....</b>	<b>53</b>
<b>Appendix B: Wiring Option configurations.....</b>	<b>55</b>
<b>Appendix C: Outline Drawing .....</b>	<b>59</b>
<b>Appendix D - Mounting the “EExde approved” version.....</b>	<b>63</b>

### LIST OF FIGURES

<i>Figure 1: Light Source – Reflector Type .....</i>	<i>6</i>
<i>Figure 2: Detector .....</i>	<i>7</i>
<i>Figure 3. Detector’s Wiring Diagram.....</i>	<i>12</i>
<i>Figure 4. Detector Terminal Board .....</i>	<i>13</i>
<i>Figure 5. Light Source Terminal Board .....</i>	<i>14</i>
<i>Figure 6. Detector/Light Source and Swivel Mount Assembly for Standard Installation</i>	<i>26</i>
<i>Figure 7. Tilt Mount Assembly.....</i>	<i>27</i>
<i>Figure 8. Detector/Source and Tilt Mount Assembly .....</i>	<i>28</i>
<i>Figure 9. Drilling Layout Dimensions for Duct Installation .....</i>	<i>31</i>
<i>Figure 10. Detector/Light Source and Duct Mount Installation scheme.....</i>	<i>33</i>
<i>Figure 11. Duct Mount Installation - Outline Drawing .....</i>	<i>34</i>
<i>Figure 12. Telescope Alignment Set .....</i>	<i>36</i>
<i>Figure 13. Detector with Cover (removed).....</i>	<i>39</i>
<i>Figure 14. Light Source - Open View .....</i>	<i>42</i>
<i>Figure 15. Alignment and Mode Selection .....</i>	<i>44</i>
<i>Figure 16. SafEye Light Source/ Detector Alignment .....</i>	<i>44</i>
<i>Figure 17. Detector’s Wiring Diagram.....</i>	<i>55</i>
<i>Figure 18. 4-20mA Source Output.....</i>	<i>56</i>
<i>Figure 19. Typical 4 Wire Controller .....</i>	<i>56</i>
<i>Figure 20. RS-485 Networking .....</i>	<i>57</i>
<i>Figure 21. Detector Outline Drawing With Swivel Mount.....</i>	<i>59</i>
<i>Figure 22. Source Outline Drawing (Reflector Type) With Swivel Mount.....</i>	<i>60</i>
<i>Figure 23. Detector and Tilt Mount Outline Drawing .....</i>	<i>61</i>
<i>Figure 24. Source and Tilt Mount Outline Drawing .....</i>	<i>62</i>
<i>Figure 25: Flame Detector Assembly - Wiring Diagram .....</i>	<i>64</i>
<i>Figure 26: OPTION A Detector Assembly - Wiring Diagram .....</i>	<i>65</i>
<i>Figure 27: OPTION B Detector Assembly - Wiring Diagram .....</i>	<i>65</i>

**LIST OF TABLES**

<i>Table 1: Model Selection Guideline for SafEye Series 300 IR Type .....</i>	<i>5</i>
<i>Table 2. LED Status Indication.....</i>	<i>9</i>
<i>Table 3. Alignment Indication LED Color.....</i>	<i>10</i>
<i>Table 4. Standard (default) 4-20mA Current for the Gas Channel.....</i>	<i>11</i>
<i>Table 5. Discrete reading of 4-20mA at different detector's modes.....</i>	<i>11</i>
<i>Table 6. Light Source Terminals.....</i>	<i>14</i>
<i>Table 7. SW1 DIPswitches Configuration .....</i>	<i>15</i>
<i>Table 8. Gas Type Calibration Setup.....</i>	<i>16</i>
<i>Table 9. SW2 DIPswitches Configuration .....</i>	<i>17</i>
<i>Table 10. SW3 DIPswitches Configuration.....</i>	<i>18</i>
<i>Table 11: Detection Distance Range .....</i>	<i>19</i>
<i>Table 12: Sensitivity Range.....</i>	<i>19</i>
<i>Table 13: Dry Contact Relays.....</i>	<i>20</i>
<i>Table 14. Detector/ Source Weight &amp; Dimensions .....</i>	<i>21</i>
<i>Table 15. Swivel Mount Kit.....</i>	<i>25</i>
<i>Table 16. Tilt Mount Kit.....</i>	<i>27</i>
<i>Table 17. Duct Mount Kit .....</i>	<i>29</i>
<i>Table 18. LED Signal Adjustment.....</i>	<i>50</i>
<i>Table 19. Maximum DC resistance at 68°F for copper wire .....</i>	<i>53</i>
<i>Table 20. Wiring length in feet (meter).....</i>	<i>53</i>



# 1. Scope

## 1.1 Product Overview

The SafEye 300 Series is an IR Open-Path Gas Detector that detects ambient combustible gases at LEL.m concentrations over a path length from 2ft (0.6m) up to 49 ft. (15 m), even in harsh environments where dust, fog, rain, snow or vibration can cause a high reduction of signal.

The shorter path lengths are usually associate with application in ducts/air intakes to provide fast response to ingress of flammable gases.

Due to its unique combination of triple optics and dual-spectrum reference sensor, the SafEye can maintain operation in up to 90% signal obscuration and  $\pm 2$  degree of misalignment.

SafEye has a fast response detection time of no more than 2-10 seconds. This feature enables an adequate time to take appropriate safety measures.

The SafEye Source and Detector unit enclosures are ATEX certified EExd flameproof or EExde (with additional separate EExe terminal box connected to the unit.)

This manual consists of a full description of the Detector and its features. It contains instructions on the installation, operation and maintenance. The system is intended to be operated by qualified personnel.

## 1.2 Document Overview

This manual describes the Detector and its features and provides instructions on the installation, operation and maintenance.

This manual is divided into separate sections as follows:

- Section 1.     **Scope** - a general introduction and overview of the product and the Manual, with a brief description of its content.
- Section 2.     **Technical Description** - the Detector's theory of operation.
- Section 3.     **Operation Mode** - the Detector's operation modes, user interface and indications.
- Section 4.     **Technical Specifications** - the Detector's electrical, mechanical and environmental specifications.
- Section 5.     **Installation Instructions**, including wiring and mode setting.
- Section 6.     **Operating Instructions** and power-up procedures.
- Section 7.     **Maintenance Instructions** and support procedures.
- Section 8.     **Troubleshooting**
- Appendix A.   **Wiring Selection Tables** for electrical wire selection according to installation configuration.
- Appendix B.   **Wiring option Configurations** - wiring diagrams for installation.
- Appendix C.   **Detector and Source Outline Drawing**

## 2. Technical Description

### 2.1 Features

- Operating distance from 2ft (0.6m) up to 49 ft (15m)
- Simultaneous detection of C<sub>1</sub>-C<sub>8</sub> flammable gases
- High Sensitivity and fast response to Hydrocarbon gases
- Continuous operation in extreme and harsh environmental Conditions
- Withstands extreme vibration conditions
- Interfaces with most commonly used control panels
- Standard 4-20mA and Dry Contact Relays Outputs
- RS-485 Output for PC Communication Network for a maximum of 64 systems
- Simple one person installation, alignment, and calibration
- ATEX Approved - EX II 2 G, EExd IIB + H<sub>2</sub> T5; EExde IIB + H<sub>2</sub> T5
- UL Approved – E209870 Class I, Group C and D
- Programmable configuration

### 2.2 Applications

The SafEye system may be used to monitor flammable gas concentration in various applications, such as fence-line monitoring and area monitoring in processing facilities, air-intakes and duct installations in various industries including:

- Petrochemical, pharmaceutical and other chemical storage and production areas.
- Flammable and toxic chemical storage sites and hazardous waste disposal areas.
- Refineries, oil platforms, pipelines, refueling stations and fuel storage facilities.
- Hazardous loading docks, transportation depots and shipping warehouses
- Engine rooms
- Compressor and pumping stations
- Hazardous enclosures and test cells
- LNG-LPG Systems
- Offshore Floating Production Storage and Shipping vessels (FPSO), and fixed oil rigs.

### 2.3 Principle of Operation

The SafEye system detects gases through a dual spectral range monitoring, analyzing the absorption of radiation caused by gases in the atmosphere and comparing it (ratio) to background atmospheric absorption.

### 2.3.1 Definitions of Terms

The following list defines gas concentrations measurement terms that are used in this manual:

- |       |   |
|-------|---|
| LEL   | Lower Explosive Limit - The minimum concentration of a substance (gas/vapor) in air mixture that can be ignited. This mixture is different for every gas/vapor, measured in % of LEL. |
| LEL.m | Integral of Concentration in LEL units (1 LEL = 100% LEL) and the operation distance, or path length, in meters (m).  |

### 2.3.2 Spectral Finger Print

Each hazardous material is detected at a specific wavelength selected according to its specific spectral absorption or "finger print". There are three IR sensors: two signals and one reference. The detection process involves two separate filters, one transmitting radiation that is absorbed by a particular gas and one that is not sensitive to it.

### 2.3.3 Optical Path

The presence of hazardous airborne vapors, gases, or aerosols in a monitored area is detected when the defined substance crosses/enters the optical path between the radiation source unit and the detector.

Hazardous gases /vapors present in the atmosphere cause absorption of the radiation pulse in the optical path between the radiating source and the detector unit at some specific wavelengths. This causes a change in the signal intensity received by the detector, which is translated into an output related to the detector's measuring scale.

The system analyzes the defined open path at the spectral bands specific to the materials being monitored. The Automatic Gain Control (AGC) unit compensates for environmental disturbances such as fog, rain, etc., through a constant comparison with its dual spectral beam.

### 2.3.4 Microprocessor Based

The incoming signals are analyzed by the built in microprocessor. A sophisticated mathematical algorithm calculates between the various functions of the detected signal thresholds. Statistics, ratio algorithms, data communications, diagnostics and other functions are performed.

### 2.3.5 Gas Sensitivity

The SafEye IR Model uses wavelengths around 3.4 $\mu$  spectral band to measure air flammability potential between the source and detector. At this wavelength, all hydrocarbon materials have a strong absorption peak. This peak enables the detector to achieve both regular sensitivity of 0-5 LEL.m or high sensitivity of 0-2 LEL.m according to functions set up.

In the short-range duct Model 301, the standard full scale is 2.5 LEL.m or 1 LEL.m by DIPSwitch.

However, since the desired detection information is air flammability and the actual measurement is radiation absorption around the 3.4 $\mu$  spectral band, the detector has a different sensitivity to different gases or gas combinations.

This difference in sensitivity is irrelevant if in the protected area the gas composition is known. However, if in a protected area the gas composition can vary substantially, then the difference in sensitivity should be considered in determining the Detector calibration.

### 2.3.6 Gas and Mixture Selection and Setting

At the 3.4 $\mu$  spectral band of the SafEye, the least sensitive gas is pure (100% vol) methane and the most sensitive gases are various mixtures of Methane with heavier alkanes where the Methane percentage is less than 90%. For pure Ethane the sensitivity is close to the high sensitivity gases and for pure Propane it lies somewhere between the two extremes. Every SafEye has 4 built-in gas calibration settings that can be changed by function set up. The setting for each Safeye is detailed on the calibration datasheet provided with each unit.

The calibration settings are designed for use in various applications:

- Gas 1 - Pure methane and is for use in methane storage and piping applications
- Gas 2 - 92% methane, 4% propane and 4% ethane (default) Universal oil and gas production mixture to be used in all cases where methane concentration in the mixture does not exceed 98%. It can also be used for pure Ethane applications.
- Gas 3 - Pure propane and is good for propane/butane detection.
- Gas 4 - 99% methane and 1% propane and is for use in detecting methane mixture with heavier gases where the methane component can vary between 100% to 95%. It is also good for protecting areas where a leak can be either pure methane or pure propane.

The four internal gas calibrations cover most of the flammable gas detection applications. Actual selections should be made by the user in consultation with experts to provide for safety requirements. However, for special cases where

none of the four calibrations are appropriate, Spectrex, through local agents can advise how to calibrate a SafEye Detector to any specific gas.

## 2.4 Product Marking

The SafEye 300 Series open path gas Detector and source unit are certified to:

1. **ATEX** Ex II 2 G per SIRA 00 ATEX 1161 & 1165  
EExd IIB +H<sub>2</sub> T5 and EExde IIB +H<sub>2</sub> T5 Amb. Temp. -40°C to +70°C
2. **UL** E209870 Class I, Group C and D

## 2.5 Models and Types

This manual includes information for SafEye Series 300 models. Table 1 identifies the detector model options in reference to the required gas type and detection range.

**Table 1: Model Selection Guideline for SafEye Series 300 IR Type**

Model	Distance		Detector*	Light Source*	Option for Duct Mount	Option for St.St Enclosure
	Ft.	m.				
301	2-11.5	0.6-3.5	OP-IL000x	OPS-LI0x	Yes	Yes
302	9.8-49	3-15	OP-IL100x	OPS-LI0x	Yes	Yes

### \* Notes

For standard installation add "S" suffix. For duct installation add "D" suffix. For St. St. version add "St" suffix after the "D" or the "S" suffix.

## 2.6 Description

The system comprises two main units; the Light Source and the Detector. The SafEye system detects gases over an open path transmitted from the Light Source to the Detector.

### 2.6.1 Light Source Unit

The Light Source unit emits IR radiation pulses, in a collimated beam (for maximum intensity) to the detector unit. The model number is OPS-LI0x (Figure 1).

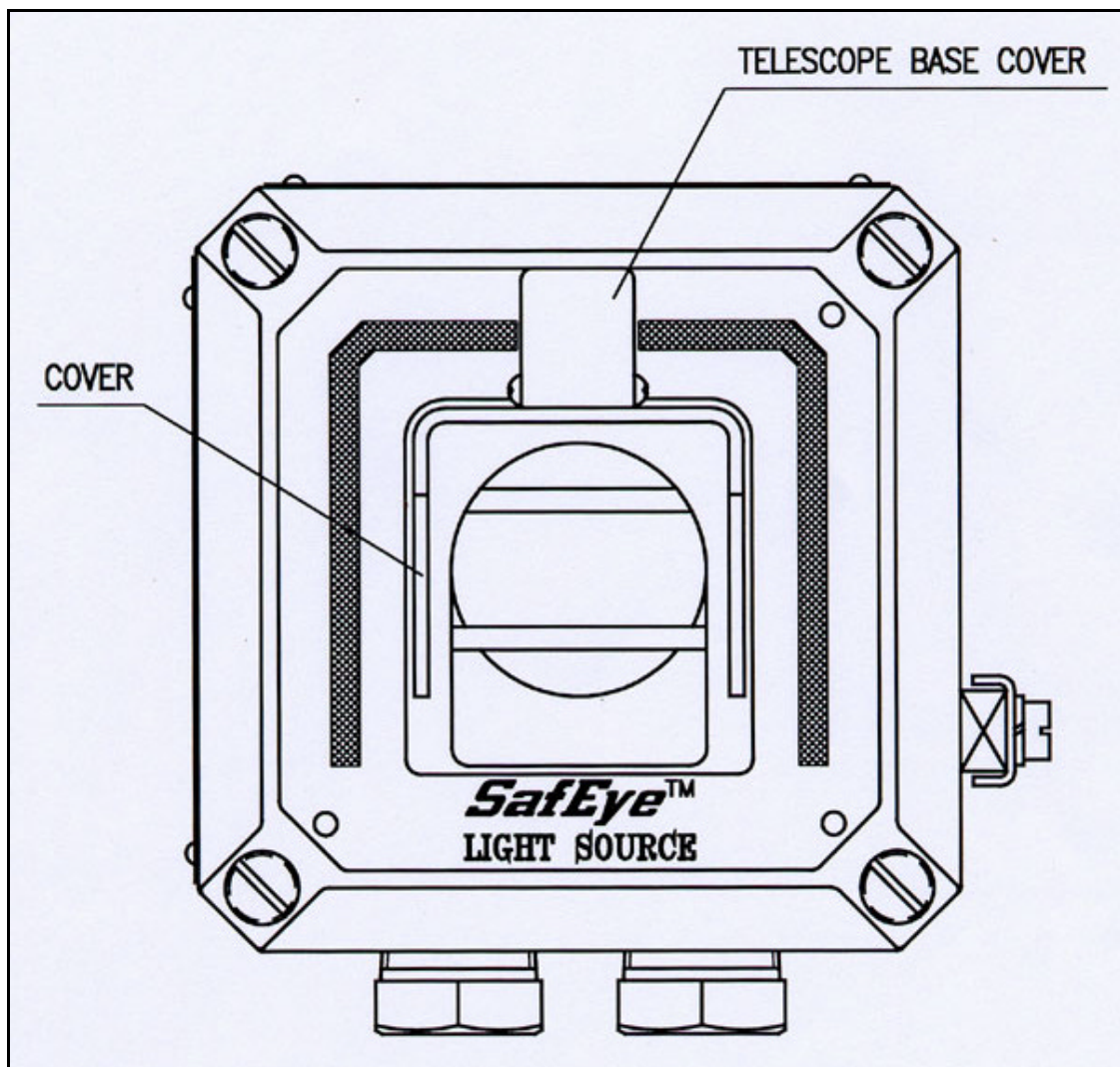

Figure 1: Light Source – Reflector Type

### 2.6.2 Detector Unit (Figure 2)

The detector's sensors receive the transmitted pulsed radiation signals from the Light Source. The signals are then amplified and fed into an analog to digital signal converter to be processed by the internal microprocessor.

When the signals drop below a prescribed level, the internal microprocessor will compensate for them. This will allow the signal to be maintained even in severe weather conditions. The data is sent to the output interface section. The signals can be sent to a standard control panel or to a central computer.

The Series 300 Detector is available in two basic types:

1. Model OP-IL000X for short-range installation
2. Model OP-IL100X for medium-range installation.

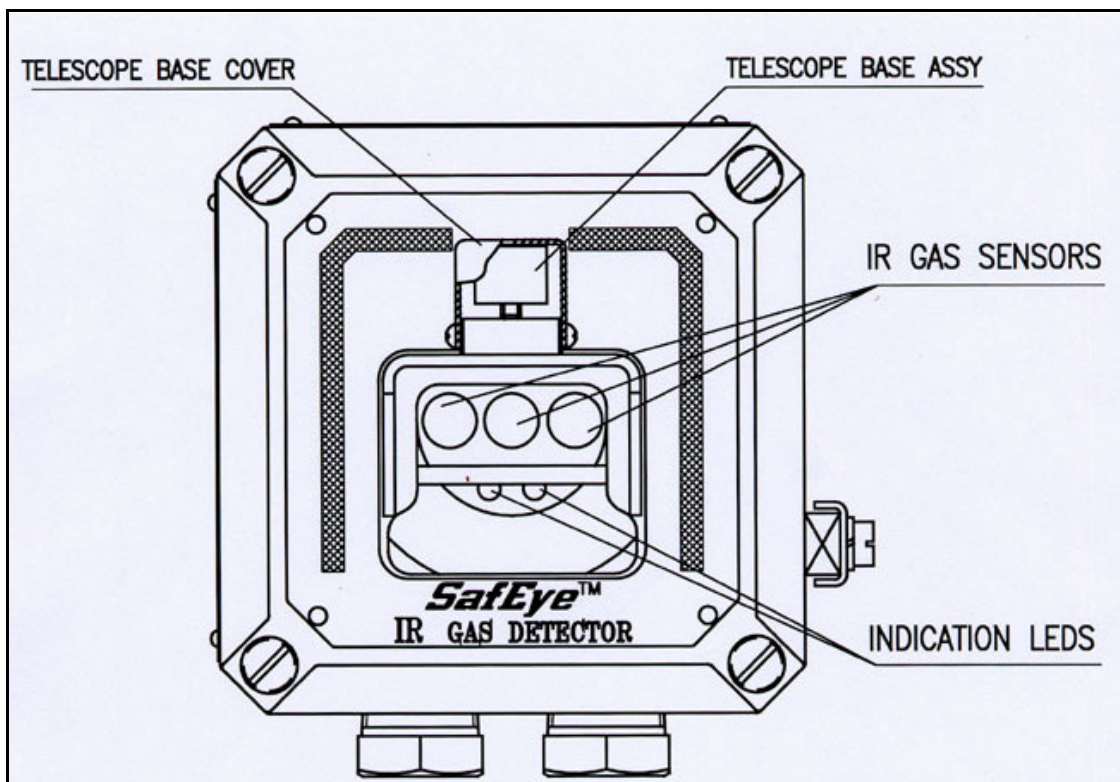

Figure 2: Detector

## 3. Operation Mode

The SafEye system has three operation modes; Normal, Alignment and Zero Calibration.

### 3.1 Normal Mode

This mode is used for gas detection. The following status signals are possible: (see Table 2 for visual indications).

Normal	- Signal received from gas detection is at safe levels.
Warning	- Gases have been detected at warning levels.
Alarm	- Gases have been detected at alarm levels.

### 3.2 Fault Mode

There are three fault types:

- **Fault 1 (2mA Output) – Non critical**

If this occurs, it is due to blockage, poor alignment, very low signal or in the case of partial obscuration or full beam block and **detection is no longer possible**. The Detector's proper operation will be restored (Auto reset) during operation if the condition causing the problem is removed or resolved. This mode will occur after a delay of 60 sec. from the moment of the fault. This delay is important to eliminate momentary obscuration due to objects/people passing through the beam.

- **Low Voltage Fault (0mA Output)**

In this case, **detection is disabled** due to low voltage being supplied to the Detector. The Detector returns to proper operation only when proper voltage level restored.

- **Fault 2 (0mA Output) – Critical**

In this case, the **detection is disabled** due to electrical / software operational failure or central device (memory, processor) fault. Such fault causes the Detector to cease operation.

### 3.3 Alignment Mode

This mode is used when the received signal needs to be measured (i.e. Installation & Periodic Maintenance). LED indications represent the received signal strength for precise alignment. There is a temporary Standby Mode to give the option of switching from Alignment Mode to Calibration Mode.

### 3.4 Zero Calibration Mode (1mA Output)

This mode zeros the base level from which the Detector will read gas. It should only be performed when there are:

- No combustible gases present
- Clear path between the Light Source and Detector
- Clear weather conditions.



Zero calibration must be done after installation, re-alignment and window cleaning, using magnetic mode selection

### 3.5 Mode Selection

A Magnetic Mode Selector is used to change to alignment and calibration modes by placing the magnet on the side of the detector (Figure 16).

### 3.6 Visual Indications LEDs

There are two indicators (LEDs) located in the detector's front window, referred to as the right and left LEDs. They display red, orange and green light that can be either 'On' steady or flashing or 'Off'

**Table 2. LED Status Indication**

Status	Remarks	Left LED	Right LED	LED Status	4-20mA Output
Normal		Green	Off	On	4 mA
Warning	See Note 4	Red	Off	On	14 mA
Alarm	See Note 4	Red	Red	On	19 mA
Fault 1		Orange	Off	On	2 mA
Fault 2		Orange	Orange	On	0 mA
Low Voltage		Orange	Orange	Both LEDs flash at rate of 2Hz	0 mA
Alignment Mode	First receives the intensity compared to the last calibration: The intensity is min. 80% of the last calibration intensity 80% - 60% 60% or less After 20 seconds the color represents the signal intensity (See Note 2).	Green	Green		0 mA
		Orange	Green		0 mA
		Red	Orange		0 mA
		See Note 1	See Note 1		0 mA
Standby mode		Green	Green	Both LEDs flash alternately at a rate of 2Hz.	0 mA
Calibration mode	See Note 3	Off	Off		0 mA

**Notes:**

- 1 The number of flashes shows the intensity of the received signals while the color represents the gain (see Table 3). The left LED shows the “tens” unit of the number while the right LED displays the “one” unit of the number of the signal intensity. Each LED will flash 0 to 9 times (9 being the maximum possible signal intensity). When the left LED has reached its highest signal, look at the right LED for fine adjustment.

**Table 3. Alignment Indication LED Color**

Left LED	Right LED	Gain
Red	Red	3
Orange	Orange	2
Green	Orange	1
Green	Green	0

- 2 After 20 minutes at alignment mode the detector will return to normal mode.
- 3 After zero calibration is finished, the detector will return to normal mode and the signal intensity will be saved for next alignment comparison.
- 4 The 4-20mA level in this Table refers to discrete indication option. A different (continuous reading) option is described later in section 3.7.1

**3.7 Output Signals**

The SafEye system provides the following outputs:

- Standard 4-20mA port
- Three dry contact relays
- Optional RS-485 Output for PC Communications

**3.7.1 4-20mA Current Output**

The 4-20mA output can provide the detector status measurement in one of the two following methods:

1. It can be measured proportionally (default) showing a continuous reading of the exact gas concentration (see Table 4).
2. It can be a discrete indication according to the detector mode or the Warning or Alarm signal at a defined gas concentration. Setting of this method can be done by SW3-2 selection (see Table 5).

The 4-20mA functions as current source. The maximum permitted load resistance for the 4-20mA output is 600 ohms. The minimum permitted load resistance is 100 ohms.

**Table 4. Standard (default) 4-20mA Current for the Gas Channel**

Current	Status and Description
0mA +0.5mA	Fault 2 or Low Voltage
2mA ±0.5mA	Fault 1
4mA ±0.5mA	Zero reading - No gas detected
4-20mA	Continuous measuring of gas concentration at a range between 0 and 5 LEL.m or full scale
21mA	Concentration is over the range limit (more than full scale concentration).

**Table 5. Discrete reading of 4-20mA at different detector's modes**

Current Reading	Mode	LEL.m Setting	
		301	302
0 +0.5mA	Fault 2 or Low Voltage	-	-
2 ±0.5mA	Fault 1	-	-
4 ±0.5mA	Standby	0	0
14 ±0.5mA	Warning	0.6	1
19 ±0.5mA	Alarm	1	2.5

### 3.7.2 Relays

The detector includes three relays:

- Fault relay
- Alarm relay
- Accessory relay

Fault Relay contacts are normally energized closed, and opened when in Fault condition

### 3.7.3 RS-485 Interface

The RS-485 input/output sends complete data information to a PC and receives data or control commands from the PC. The communication with the PC is operated through this interface is executed only when used with appropriate host software.

The following PC minimal hardware requirements are as follows:

- 386 PC using DOS Ver. 5.0 or higher
- 1 MB RAM.
- 2 MB free hard disk space.
- 1.2 or 1.44 MB floppy drive
- Color VGA
- RS-485 Interface Card to be defined as COM1 or COM2. Isolated Adapter is preferred.

### 3.8 Terminals

Terminal outputs are described for the Detector and the Light Source.  
For EExde version with separate EExe terminal section, see Appendix D

#### 3.8.1 Detector Terminal

Terminal Wiring: Figure 3 displays a schematic diagram of the terminals and Figure 4 shows their location.

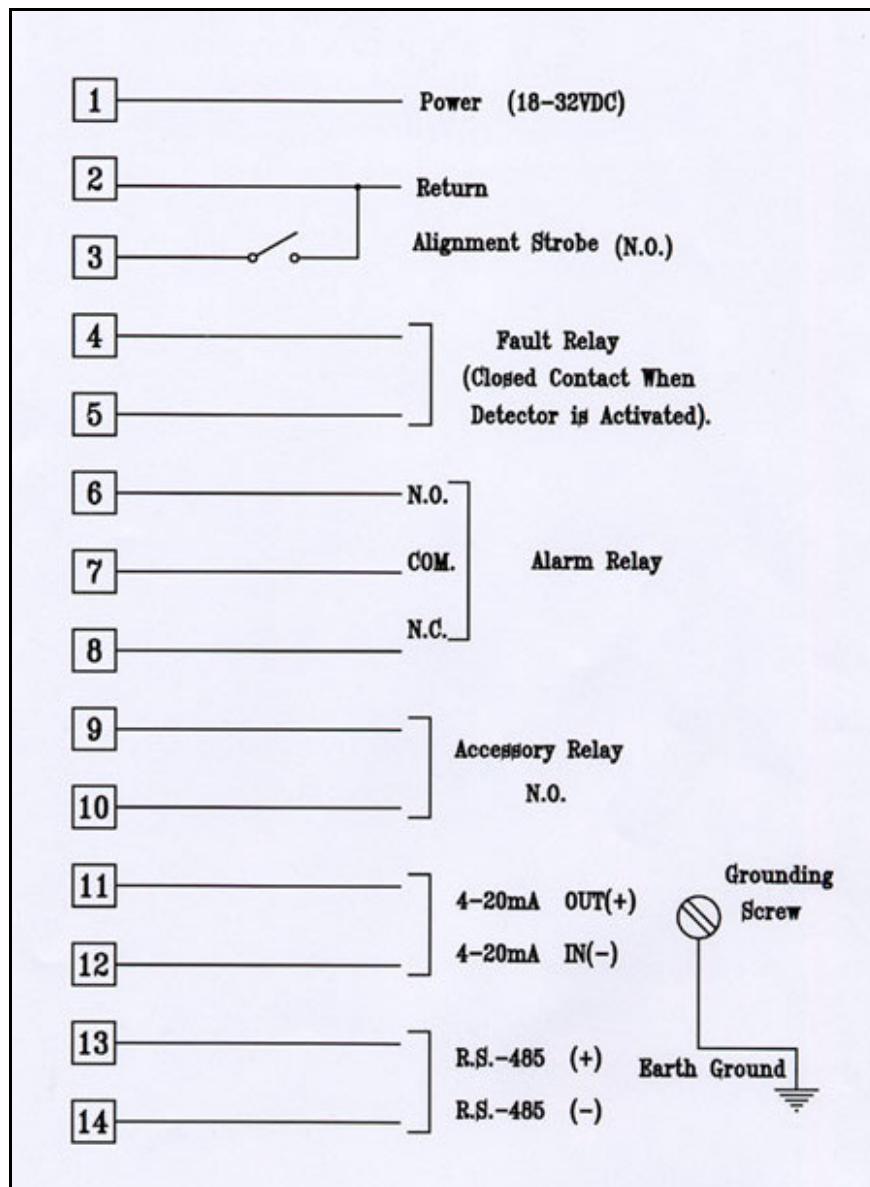
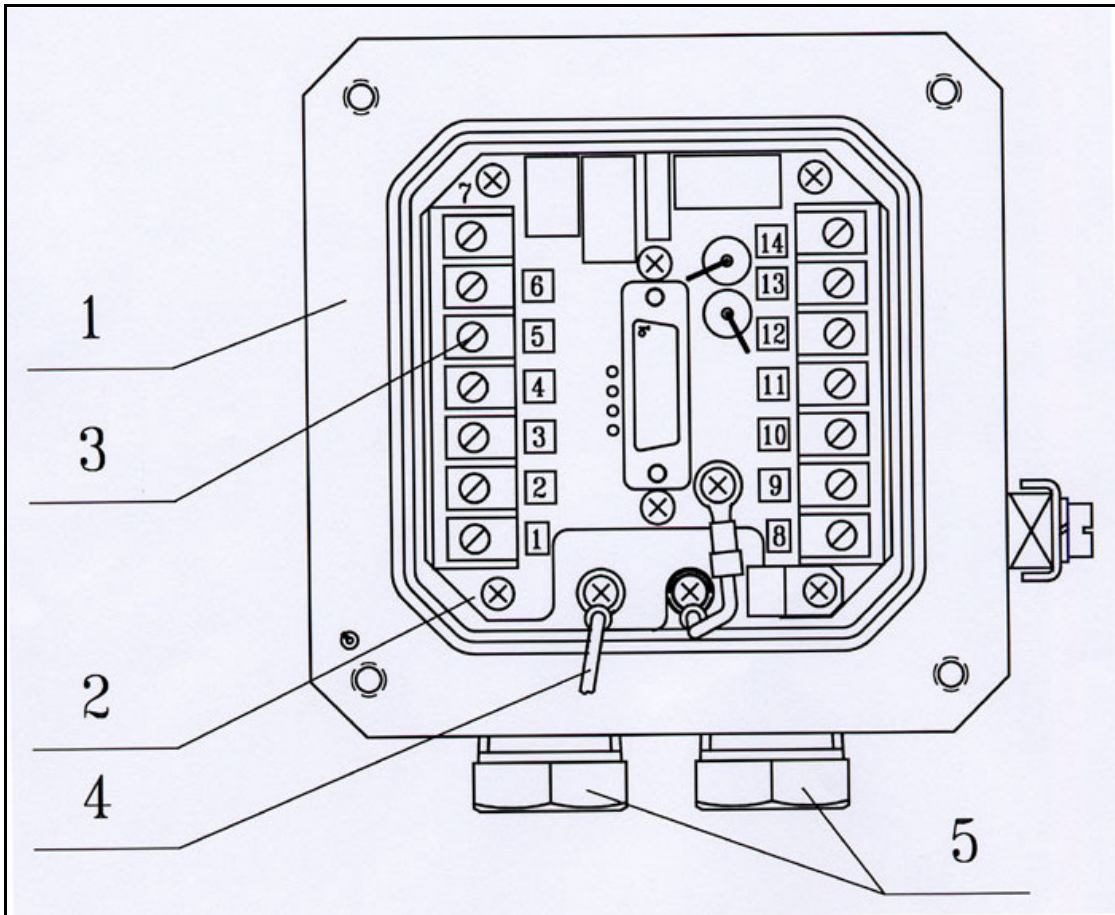

Figure 3. Detector's Wiring Diagram



Description	
1	Detector Cover
2	Terminal Board
3	Terminal Screw
4	Securing Cable
5	Conduits

Figure 4. Detector Terminal Board

### 3.8.2 Light Source Terminals

Figure 5 shows the terminal board and Table 6 describes their use.

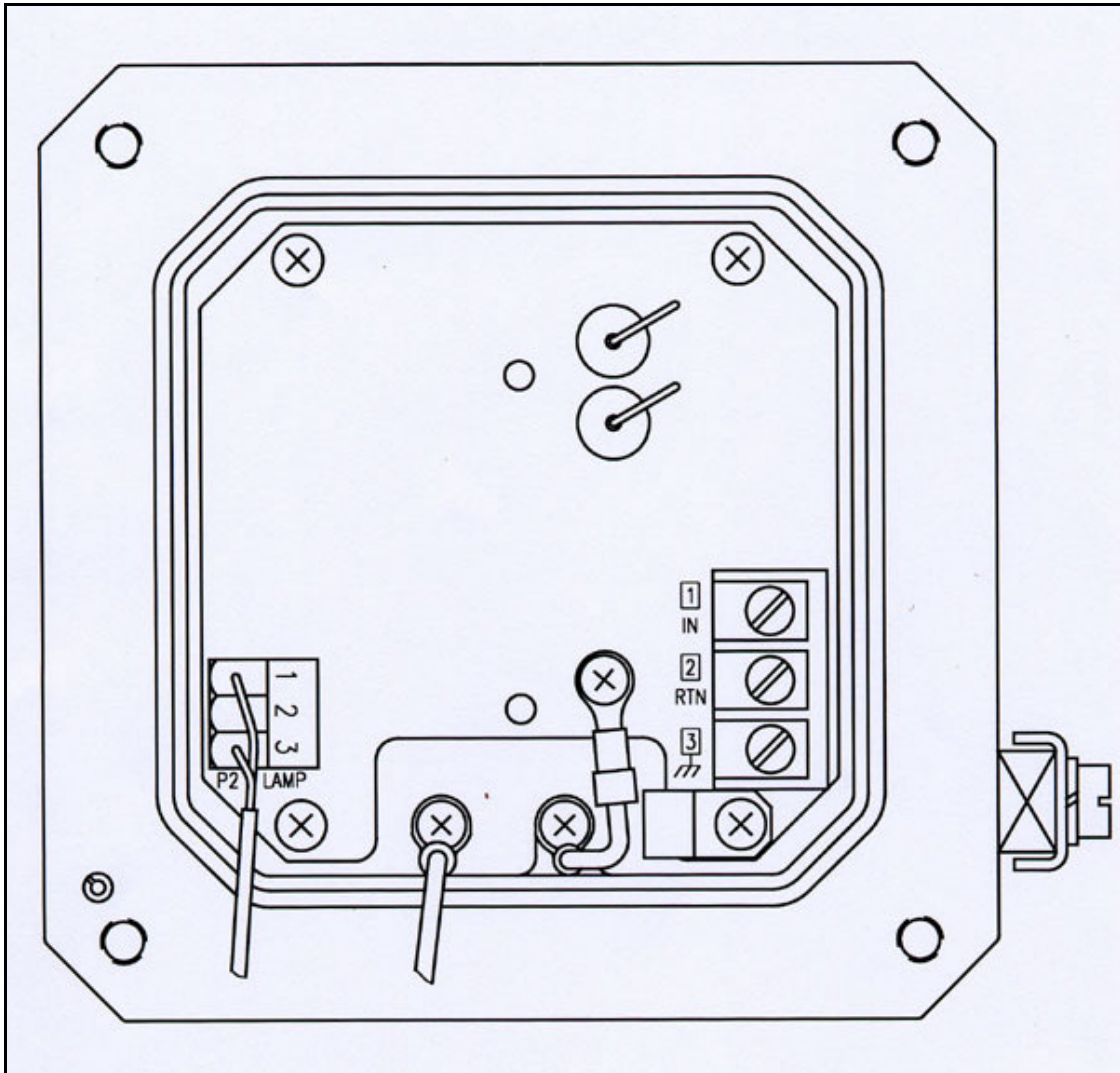

Figure 5. Light Source Terminal Board

Table 6. Light Source Terminals

Light Source Terminal Number	Description
1	VIN
2	RTN



### 3.9 System Setup

#### 3.9.1 Detector Setting

The detector consists of the following DIPswitches, which enable the user to adapt the detector operation to specific application:

- SW1 *Function Selection Switch*. Contains 8 DIPswitches. Used for Calibration of different gas selection, response time control and Relays response configuration (see table 7)
- SW2 *Address Selection Switch*. Contains 8 DIPswitches. Used for Detector's address setting and 4-20mA output configuration setting (see table 9)
- SW3 *Alarm Options Selection Switch*. Contains 4 DIPswitches. Used for Detector's Alarm Latching configuration and 4-20mA level reading configuration (see table 10)

#### ***Function Selection Switch:***

Table 7 describes SW1 DIPswitches position and the required function for setting the detector according to the necessary configuration

**Table 7. SW1 DIPswitches Configuration**

Switch No.	Off position	On position	Default setting
1	Not Used		on
2	Not Used		off
3	Gas type control bit 0 at "0" (see note 1 below)	Gas type control bit 0 at "1" (see note 1 below)	on
4	Gas type control bit 1 at "0" (see note 1 below)	Gas type control bit 1 at "1" (see note 1 below)	off
5	Full scale sensitivity is 0-5 LEL.m (see note 2 below)	Full scale sensitivity is 0-2 LEL.m (see note 2 below)	off
6	Zero calibration is performed according to background	Gas level detection performed without background Zero calibration	off
7	Accessory Relay is activated at Warning level	Accessory Relay is activated at Alarm level (with the Alarm Relay)	off
8	Accessory Relay is activated according to SW1-7 position	Accessory Relay is Activated at Power on continuously (used as End of Line)	off

## Notes:

- 1 Four Gas types can be selected for maximum compatibility to Gas spectral properties. The selection of the appropriate type is defined by pre-setting of SW1-3 and SW1-4 according to the following table:

**Table 8. Gas Type Calibration Setup**

bit # 0 position (SW1-3)	bit # 1 position (SW1-4)	Detected Gas Type	Gas type as defined in Section 2.3.6
off	off	Methane	Gas 1
on	off	Mixture	Gas 2
off	on	Propane	Gas 3
on	on	Mixture	Gas 4

- 2 In Model 301 the standard full scale is 2.5 LEL.m and 1 LEL.m by DIPSwitch.

***Address Selection Switch***

The Address selection Switch provides up to 64 different addresses for the detector upon a network installation. Each detector can be recognized at its specific address in RS485 network. The address should be determined by a pre-setting of SW2-1 to SW2-6 switches.

**Attention!**

SW2-7 and SW2-8 should be always at on.



Table 9 describes SW2 DIPswitches position and the required function for setting the detector according to the necessary configuration

**Table 9. SW2 DIPswitches Configuration**

Switch No.	Switch Definition	Off position	On position	Default setting
1	Address bit 0 (LSB)	0	1	off
2	Address bit 1	0	1	off
3	Address bit 2	0	1	off
4	Address bit 3	0	1	off
5	Address bit 4	0	1	off
6	Address bit 5 (MSB)	0	1	off
7	4-20mA direction setting (1)	N/A	4-20mA output at source position	on
8	4-20mA direction setting (2)	N/A	4-20mA output at source position	on

### ***Alarm Options Selection Switch***

This switch is used for the following function setting:

- Selection of the Alarm status to be latched or to auto-reset after the Alarm disappears.
- Selection between two different 4-20mA reading modes, continuous analog reading or discrete level reading which appropriate to the detector's status.

This switch also enables impedance matching to the serial link by providing a connection to a loading resistor through the switch.

Table 10 describes SW3 DIPswitches position and the required function for setting the detector according to the necessary configuration

**Table 10. SW3 DIPswitches Configuration**

Switch No.	Off position	On position	Default setting
1	Non latching Alarm Relay	Alarm Relay latches. Latching reset can be provided by momentarily power disconnection or when the detector is set to alignment mode.	off
2	Continuous reading of the 4-20mA output reading	Discrete Reading of the 4-20mA output according to the detector status (see table 5).	off
3	Non-latching Alarm indications during Blocking Mode	Alarm indications are latched when the detector turns to Blocking Mode from Alarm position. Latching reset can be provided only if the detector turns to Normal Mode.	off
4	Normal Position (open)	Communication line termination for impedance matching	off

## 4. Technical Specifications

### 4.1 General Specifications

**Detected Gases:** Simultaneous detection of C<sub>1</sub>-C<sub>8</sub> flammable gases

**Detection Distance range:**

**Table 11: Detection Distance Range**

Model No.	301	302
Distance (ft)	2-11.5	9.8-49
Distance (m)	0.6-3.5	3-15
Response Time	2 Sec.	10 Sec.

**Spectral Response:** 3.0 - 4.0 micron

**Sensitivity Range:**

**Table 12: Sensitivity Range**

	301	302
Standard	0-2.5 LEL.m	0-5 LEL.m
DIPswitch	0-1 LEL.m	0-2 LEL.m

**Field of View:** Line of Sight

**Alignment Tolerance:** ± 2°

**Drift:** Long term ± 5% of full scale

**Temperature Range:** -40°F (-40°C) to +158°F (+70°C)

**Immunity to false alarm:** Does not produce false alarm by Hydrocarbon Flames and most of IR Radiation Sources.

## 4.2 Electrical Specifications

- **Operating Voltage:** 18- 32 VDC
- **Power Consumption**
  - Detector     150 mA @ 24 VDC (200 mA Peak)
  - Source        100 mA @ 24 VDC (220 mA Peak)
- **Electrical input protection:**  
The input circuit is protected against voltage-reversed polarity, voltage transients, surges and spikes according to MIL-STD-1275A.
- **Electrical Interface** (see figure 4)
- **Electrical outputs**
  - A. **4-20mA Current Output:**  
The 4-20mA is source configuration. The maximum permitted load resistance is 600 Ohm.  
  
Two 4-20mA options:
    - Continuous reading - **default**            (See Table 4)
    - Discrete reading                                (See Table 5)
  - B. **Communication Network:**  
The Detector is equipped with an RS 485-communication link that can be used in installations with computerized controllers. It enables continuous communication with up to 64 Detectors.
  - C. **Relays Output:**  
The Detector include up to three relays.

**Table 13: Dry Contact Relays**

Relay	Type	Normal	Maximum Ratings
Alarm	SPDT	NO, NC	2A at 30VDC or 0.5 at 250 VAC
Accessory	SPST	NO	5A at 30VDC or 250 VAC
Fault *	SPST	NC	5A at 30VDC or 250 VAC

\* *Fault Relay is normally energized, the contact will be closed, and when it is in Fault situation, the relay is opened.*

### 4.3 Mechanical Specifications

Enclosure:	The source and detector housings are made of either anodized aluminum with less than 1% Mg with an epoxy enamel finish, or St.St. 316L enclosure with electro polish finish The back covers are all sealed with special "O" rings to prevent intrusions such as dust, salt and sprays. The circuit boards are conformal coated and protected from mechanical vibrations and a slight impact.
Explosion Proof:	Alignment Base is Stainless Steel 316L for all models. ATEX (Cenelec) Ex II 2 G, EExd IIB + H <sub>2</sub> T5 EExde IIB + H <sub>2</sub> T5 Temp -40°F (-40°C) to 158°F (70°C) UL E209870, Class I Group C and D hazardous Location FM Class I Div. 1 Group B, C, and D. (Designed to meet) Class II Div. 1 Groups E, F and G.
Electrical Modules:	Conformal coated.
Electrical connection:	(Two options - specified at time of order) 2 X M25 (ISO) or 2 X 3/4" - 14NPT conduits.
Water and dust tight:	IP 66 and IP 67 NEMA 250 type 6p
Weight & Dimensions	See Table 15

**Table 14. Detector/ Source Weight & Dimensions**

Detector/ Source type and application	Al. enclosure		St.St. enclosure		Dimensions	
	Lb	Kg	Lb	Kg	Inch	mm
Detector for Duct Mount	8.1	3.7	13.4	6.1	5.2x5.2x4.7	132x132x120
Detector for Standard Mount	8.8	4.0	14.4	6.55	5.2x5.2x9	132x132x230
Source for Duct Mount.	8.5	3.9	13.8	6.3	5.2x5.2x4.7	132x132x120
Source (reflector)	9.5	4.3	14.9	6.8	5.2x5.2x9	132x132x230

#### 4.4 Environmental Specifications

The SafEye system is designed to withstand harsh environmental conditions. The Source and Detector units compensate for adverse conditions while maintaining accuracy.

- **High Temperature:**  
 Designed to meet MIL-STD-810C, method 501.1 procedure II  
 Operating temperature: +158 °F (+70 °C)  
 Storage temperature: +158 °F (+70 °C)
  
- **Low Temperature:**  
 Designed to meet MIL-STD-810C, method 502.1, procedure I  
 Operating temperature: -4 °F (-20 °C)  
 Storage temperature: -40 °F (-40 °C)
  
- **Humidity:**  
 Designed to meet MIL-STD-810C, method 507.1, procedure IV  
 Relative humidity of up to 95% for the operational temperature range.
  
- **Salt and Fog:**  
 Designed to meet MIL-STD-810C, method 509.1 procedure I.  
 Exposure to a 5% salt solution for 48 hours.
  
- **Water and Dust:**  
 IP67 per En60529  
 IP66 per En60529  
  
 Dust: Totally protected against dust.  
 Liquids: Protected against immersion between 15 cm and 1m in depth.  
 Protected against all water jets from all directions.
  
- **Shock and Vibration:**  
 Vibration: Designed to meet MIL-STD-810C, method 514.2, procedure VIII.  
 Mechanical Shock: Designed to meet MIL-STD-810C, method 516.1, procedure I.
  
- **Electromagnetic Compatibility (EMC):**  
 The detector is designed and approved according to the following EMC requirements:
 

Electrostatic Discharge (ESD)	IEC1000-4-2:1995-1
Conducted emission	EN55011, Class B
Radiated emission	EN55011, Class B
Radiated immunity	ENV50140:1994 (80-1000 MHz)
EFT/B	IEC801-4: 1988

## 5. Installation Instructions

The Detector and Light Source units can be installed and maintained with the use of general-purpose common tools and equipment. The installation procedure has to be performed by suitably qualified personnel.

### 5.1 Introduction

This section does not attempt to cover all of the standard practices and codes of installation. Rather, it emphasizes specific points of consideration and provides some general rules for suitably qualified personnel. Special safety precautions are stressed wherever applicable.

### 5.2 General Considerations

#### 5.2.1 Personnel

Only suitably qualified personnel, familiar with the local codes and practices, trained for gas detection maintenance should be employed. Wiring should only be performed or supervised by someone with knowledge of electronics and in particular wiring installation.

#### 5.2.2 Tools Required

The SafEye system requires the following tools:

- Set of screwdrivers
- Set of hex keys/Allen wrenches (supply with commissioning kit)
- Voltage Multimeter

#### 5.2.3 Site Requirements

The installation position of the SafEye system must take into account if the gas being monitored is heavier or lighter than air, the prevailing wind directions and the individual site requirements.

The site selected must give the Detector a direct view to the Source.

The mounting point for each item should be secure and stable with minimal vibrations.

Equipment should be either mounted in a position where it cannot be knocked out of alignment, or guarded from physical impact.

#### 5.2.4 The Source and Detector

The appropriate Detector should be selected for the length of open path to be monitored. To allow for ageing of the Source and a reduction of the IR signal due to adverse weather, we recommend using a Detector that is not at the limit of its operating range. As a guide, select a Detector that is installed at a distance from the Source of not more than 75% of the specified operating distance. In severe weather conditions such as offshore oil production and exploration, this should be reduced to 50%.

The open path between the Source and Detector and the immediate surroundings should be kept clear of obscuration that might hinder the free movement of air in the protected area or block the infrared beam.

### 5.2.5 Guidance Tips for Gas Detector Locations

Guidance Tips for Gas Detector locations in order to provide the best detection coverage:

1. Below potential leak source for heavier than air gases
2. Above potential leak sources for lighter than air gases
3. Near to leak sources along the expected leak trajectory, taking into account prevailing wind directions
4. Between leak source and potential ignition sources
5. In area with expected heavy fog, rain or snow, consider the effect of long-range installation and install the detector at shorter range with the maximum intensity model available.

### 5.3 Preparations for Installation

1. Upon receipt, verify the appropriate Purchase Order and record the Part Number and Serial Number of the Source and Detector units in the appropriate Log Book.
2. Carefully unpack the following equipment observing any instructions printed on or contained in the packaging list. Check the contents for any possible damage caused from shipping and handling. In the event of damage or loss in transit, notify the carrier and your Supplier immediately.

The System should include the following (in addition to this manual):

- Detector unit
- Source unit
- Two tilt or swivel Mounting Bases – one for the Detector and one for the Light Source.
- Telescope Kit
- Functional Filter
- Magnetic Mode Selector

Notes:

- 1 The Magnetic Mode Selector, the Calibration Filter and the Telescope Kit are used during each SafEye's installation and then removed. They can be reused for all other SafEye installations on the site. Therefore, only one set is provided for several detectors.
- 2 There are two different Telescope Kits:
 

For standard installation	P/N 794110
For Duct installation	P/N 794245
- 3 There are two different types of Functional Filter. One for standard mount and the other for Duct Mount. Each type has five different models for different gas reading.
 

For standard installation	P/N 794260 - 1 to 5
For Duct installation	P/N 794220 - 1 to 5



### 5.4 Mounting for Standard Open-Path Installation

The following instructions are applicable for both the Light Source unit and the Detector unit. The detector may be mounted on special Swivel Mounts (see 5.4.1) or

- i. Tilt Mounts (see 5.4.3)
- ii. Duct mounts – (see 5.5)
- iii. Also see appendix D if EExde version used

#### 5.4.1 Swivel Mount Kit

##### Note

For Aluminum and St. St. detector enclosure use Swivel Mount:

- P/N 794765 for inches measure
- P/N 794765-1 for metric measure.

The Swivel Mounts models are made of St. St. 316L.

**Table 15. Swivel Mount Kit**

Item	QTY	Location
Swivel Mount	1	
Screw 1/4"-20UNC or M6 x 1P	4	Detector - Holding plate
1/4" Spring Washer	4	Detector - Holding plate

#### 5.4.2 Swivel Installation (Figure 6)

- 1 Place the swivel mount Securing Plate (2) in its designated location and secure it with four M6 or 1/4"-20UNC screws (9), placed 3 in. (76.2 mm.) apart.

##### Note

Skip this step if the mounting is already installed. Also detector removal for maintenance purpose does not require Swivel Mount removal.

- 2 Unpack the detector carefully
- 3 Place the detector with its conduit inlets/electrical entries pointing down on the holding plate of the swivel mount (10). Secure the detector by four 1/4"-20UNC allen screws or M6 x 1P (8) with 1/4" spring washers from the swivel mount kit (use No. 5 Hex Key for M6 screws, or 3/16" Hex Key for 1/4"-20UNC screws).
- 4 Tighten the three locking 3/8"-24UNF screws (5) of the swivel mount ring until the friction in the ball joint holds the detector in its position. Yet, still permits it to be moved by hand-applied force (use 3/16 Hex Key).
- 5 Point the detector towards the Light Source and make certain that the view of the area is not obstructed. Secure the detector in that position by tightening the locking screws of the swivel mount ring.
- 6 Repeat mounting and Swivel Mount installation described in this chapter for installing the Light Source.

The detector is now correctly located and ready for the electrical connection to the system prior to fine alignment.

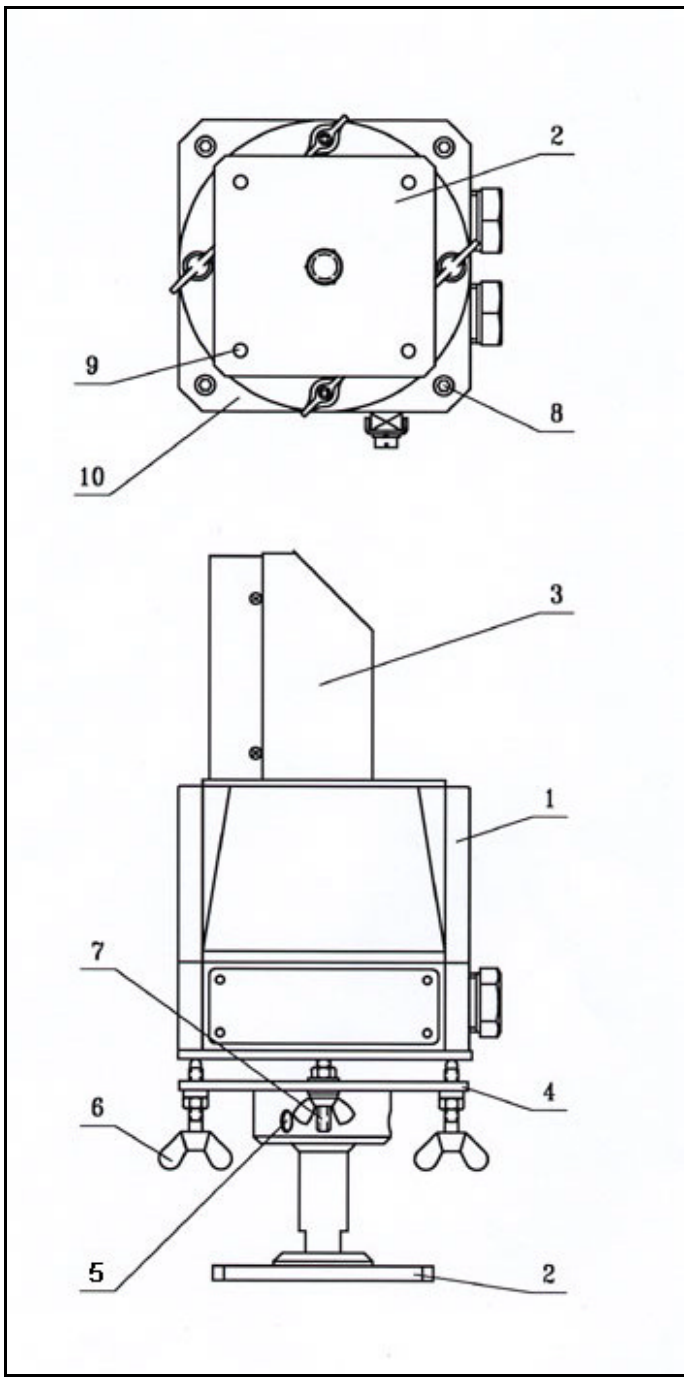

Description	
1	Detector / Light Source Assembly
2	Swivel Mount Securing Plate
3	Protective Front Cover
4	Swivel Mount Alignment Plate
5	Swivel Mount Locking Screws
6	Vertical Adjustment Screws
7	Horizontal Adjustment Screws
8	Detector Screws
9	Swivel Mount Plate Securing Screws
10	Swivel Mount Holding Plate

Figure 6. Detector/Light Source and Swivel Mount Assembly for Standard Installation

### 5.4.3 Tilt Mount Kit

The Tilt Mount kit includes the items listed in Table 16 as follows:

**Table 16. Tilt Mount Kit**

Item	Qty	DWG
Tilt Mount	1	799220
Cap Socket	1	Screw 5/16 - 18 UNC - 2H 3/4" St.St.
Spring Washer	1	Spring Washer 5/16" St.St.
Detector Base Assembly	1	799110
Cap Socket Screw	4	Screw 1/4" - 20 UNC - 3A x 1/22
Spring Washer	4	1/4" St.St

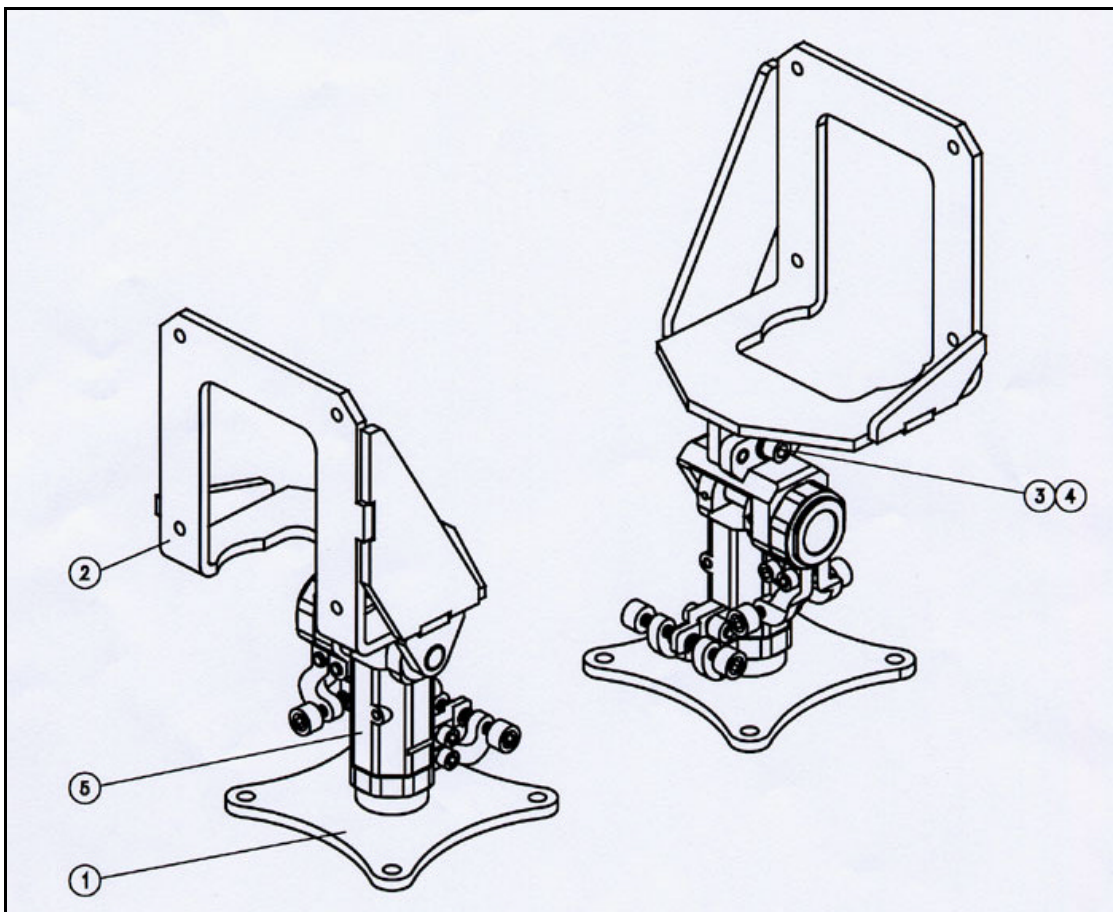

Description			
1	Tilt Mount	4	Spring washer
2	Detector Base	5	Holding Plate
3	Cap Socket		

*Figure 7. Tilt Mount Assembly*

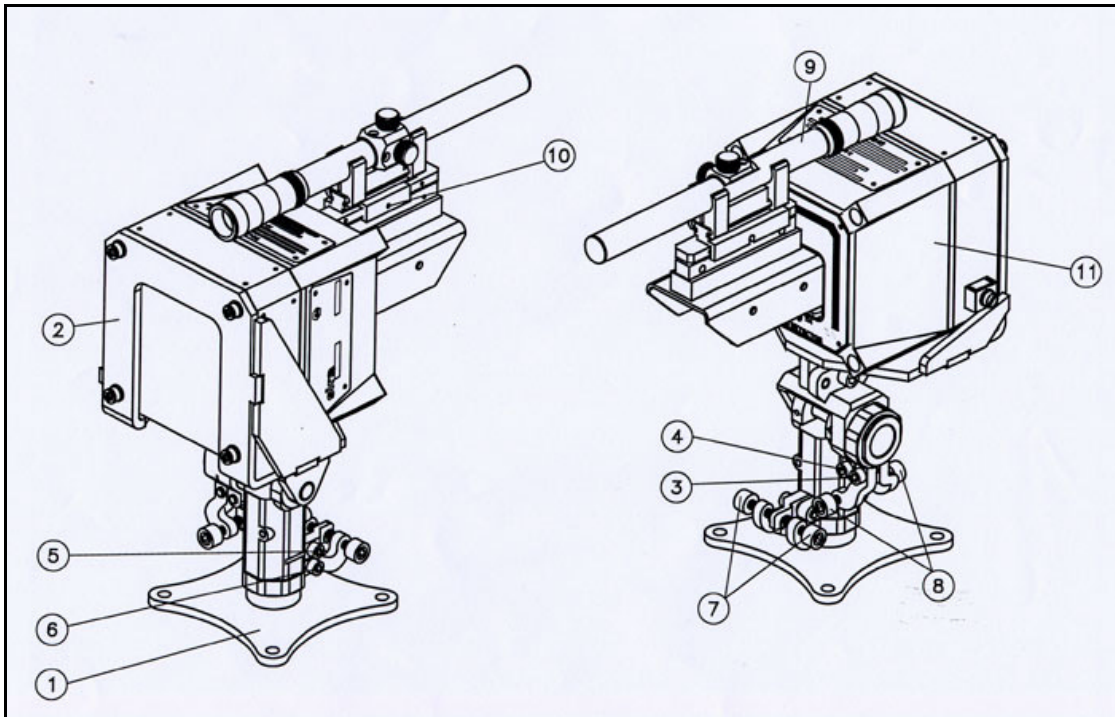

Description			
1	Tilt Mount Holding Plate	7	Vertical fine alignment screw
2	Detector base	8	Horizontal fine alignment tighten screw
3	Horizontal crude alignment tighten screw	9	Telescope
4	Horizontal fine alignment tighten screw	10	Telescope tightening bolt
5	Vertical fine alignment tighten screw	11	Detector / Source
6	Vertical crude alignment tighten screw		

Figure 8. Detector/Source and Tilt Mount Assembly

#### 5.4.4 Detector / Source Installation (Figure No. 7 and 8)

1. Place the Tilt Mount holding plate (Item 1) in its designated location and secure it with (4) fasteners through four (4) holes dia. 8.5mm.
2. Install the Detector Base Assy. (Item 2) on the Tilt Mount use cap socket screw (Item 3) and Spring Washer (Item 4).

Notes:

- 1 Skip steps 1 and 2 if the Tilt Mount is already installed.
  - 2 Detector removal for maintenance purpose does not require Tilt Mount removal
3. Place the detector, with its conduit/cable inlets pointing downwards on the detector base assy. of the Tilt Mount (Item 2). Secure the detector with four 1/4" - 20 UNC - 3A x 1/2" screw with No. 1/4" spring washers to the Tilt Mount. Use 1/4" Hex Key for 3/16" screw.
  4. Repeat 1 - 2 to install the Source

#### 5.5 Mounting for Duct Installation

The following instructions are applicable for both the Source unit and the Detector unit.

The detector may be mounted on a special Duct Mount. The Duct Mount enables the detector to be rotated up to  $\pm 3$  degrees in the X-Y directions in order to provide fine alignment.

For duct installation use Duct Mount P/N 794716.

The Duct Mount Kit supplied with the item listed in Table 17 as follows:

**Table 17. Duct Mount Kit**

Item	Qty
Duct Mount Set	1
Open & closed Wrench No. 10 key	1 per installation
Closed No. 10 Key	1 per installation

##### 5.5.1 Duct Mount Set (Figure 10, 11)

The Duct Mount set consists of Fitting Plates, Sealing Rings, Windowed plate, and securing elements combined with appropriate screws and nuts. It provides a reliable attachment of the detector to the air intake as well as good sealing and accurate alignment capability.

### 5.5.2 Duct Alignment Set (Figure 12) and Accessories

Air Duct Installation has a limitation, which is the disability of viewing the Detector's front and performing fine alignment through detector aiming such as performed in standard installation. As a result, fine alignment of the Detector's Mount should be performed before the detector assembly is mounted to it.

The Alignment Set solves this problem by enabling the installer to align the Detector Mount first, and then to install the Detector. The Alignment Set includes a Mount that is identical to the Detector Mount Surface and a telescope that is installed in the middle of the Mount Surface. The Telescope is centered in the Duct mount in a way that it is located in the same optical axis as the detector that will be mounted later in the same location.

The Accessories supplied with the kit includes one No.10 Key for installation and for alignment. One Accessories Set is supplied for each installation.

### 5.5.3 Duct Installation - Surface Preparation (Figure 9)

The following instructions are applicable for both the Light Source unit and the Detector unit.

1. Check the Air Duct Installation Surface (1) stability. It should be as near as possible to a rigid girder connection in order to assure proper support to the mounting and the unit. Also the surface must be stable and free of vibrations.
2. Locate the best installation surface for the Detector/ Light Source. The location of the central point of each Duct Hole (3) should be at the same distance from the surface edge. This will provide that both Detector and Source optical axis will be in parallel to the Air Duct wall lines such that any blocking in the interior area will be prevented.
3. Preparation of the surface: Prior to hole drilling, it should be verified that the Installation surface is straight, clean and free of corrosion.  
Drilling and cutting: Mark the Location and dimensions of the Installation

Figure 9 show surface drilling dimensions. Drill the Duct Hole (3) and the Screw Holes (2) carefully.

#### **Caution!**

Since the installation is done in a potentially explosive, any workmanship in the installation area should be performed under the appropriate rules and regulations.



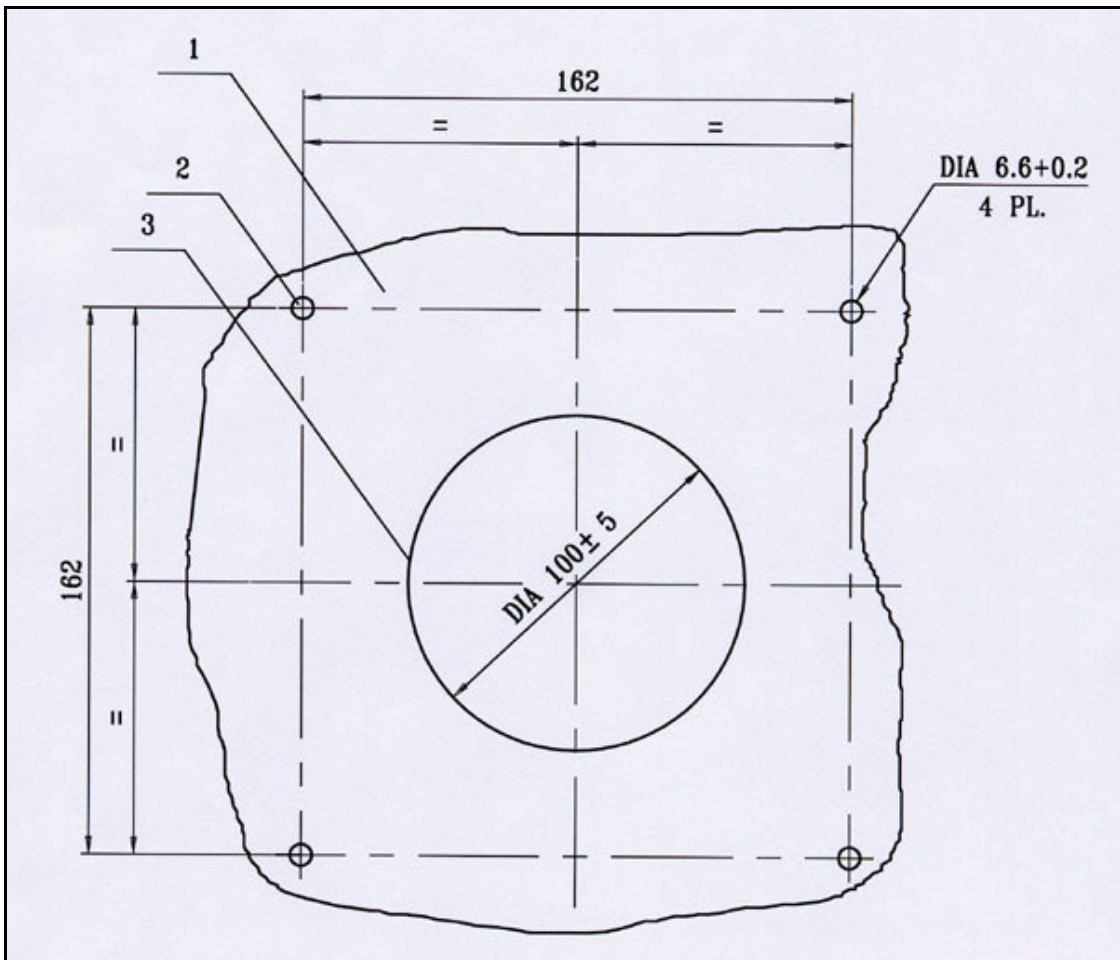

Description	
1	Air Duct Installation Surface
2	Duct Mount Screw Securing Hole
3	Hole for Detector / Light Source

Figure 9. Drilling Layout Dimensions for Duct Installation

#### **5.5.4.Duct Mount Installation (Figures 10,11)**

The following instructions are applicable for both the Light Source unit and the Detector unit.

1. Insert the first Internal Plate (1) through the Air Duct Hole. Hold it by hand and press the Base Plate Gasket (2) to the Installation Surface against the Internal Plate. The Internal Plate Screws should be inserted into the Gasket holes and hold it from falling. Then remove your hand and repeat the process for the second Internal Plate.
2. Attach the Base Plate (3) to the Gasket (2) carefully. The Internal Plate screws should be inserted slightly to the Base Plate holes.
3. Secure the Base Plate to the Installation Surface using four Nuts and Flat Washers (4).
4. Attach the Window Plate (5) by threading its holes on the Base Plate Screws. The Window (7) Protection Ring of the plate should be directed outside. Secure it by four Nuts and Flat Washers (6).
5. Alignment Plate installation: Screw together the Internal Vertical Alignment Nut and the Washer (9) to the Base Plate Screws. Then thread the Alignment plate (8) on the screws. Connect the two External Alignment Nuts and Flat Washers (10) without fastening. The Plate is now connected.
6. Connect the Horizontal Alignment Screw with the Nut and Flat Washer (11) directed according the illustration. The Alignment Plate should be held but set free for alignment.

At this point, the Duct Mount is ready for alignment.



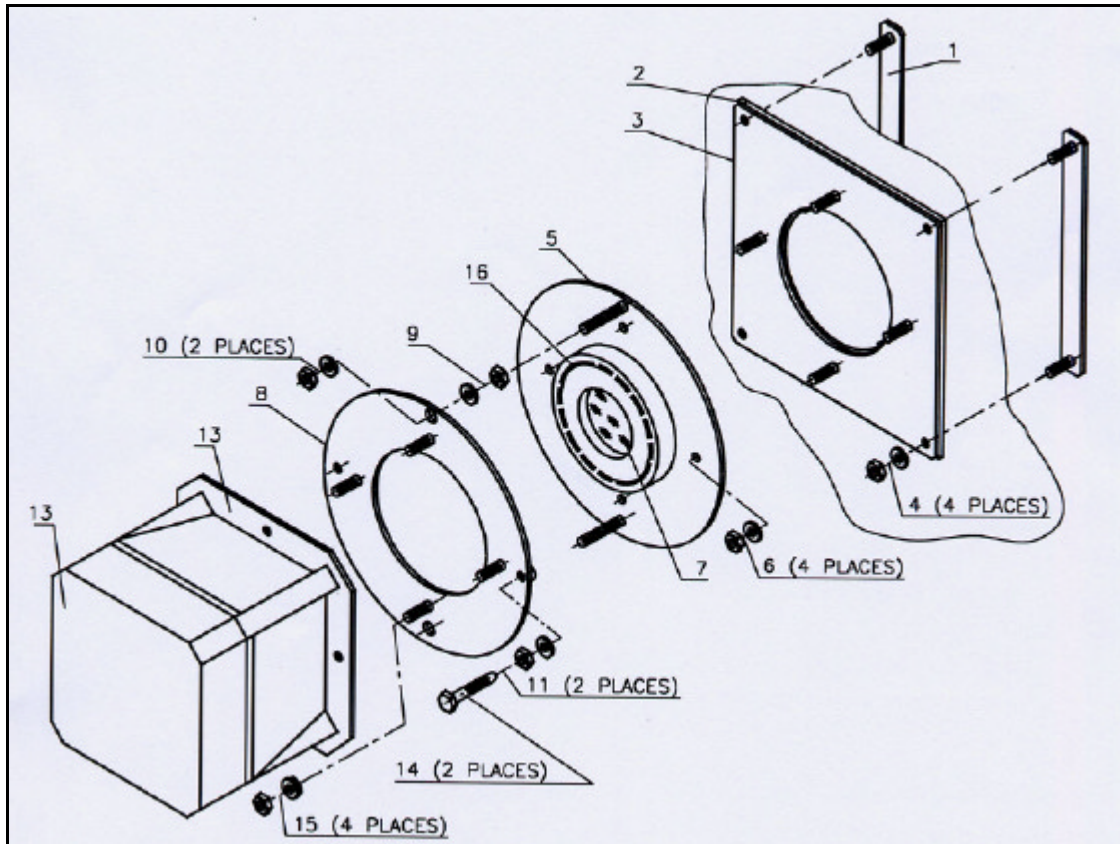

Description			
1	Internal Plate	9	Internal Vertical Alignment Nut and Flat Washer
2	Base Plate Gasket	10	External Alignment Nut and Flat Washer
3	Base Plate	11	Horizontal Alignment Nut and Flat Washer
4	Base Plate Securing Nut and Flat Washer	12	Detector / Light Source Plate
5	Window Plate	13	Detector / Light Source
6	Window Plate Nut and Flat Washer	14	Horizontal Adjustment Locking Screw Washer
7	Window	15	Detector/ Light Source Securing Nut and Flat Washer
8	Alignment Plate	16	Window Nut

Figure 10. Detector/Light Source and Duct Mount Installation scheme

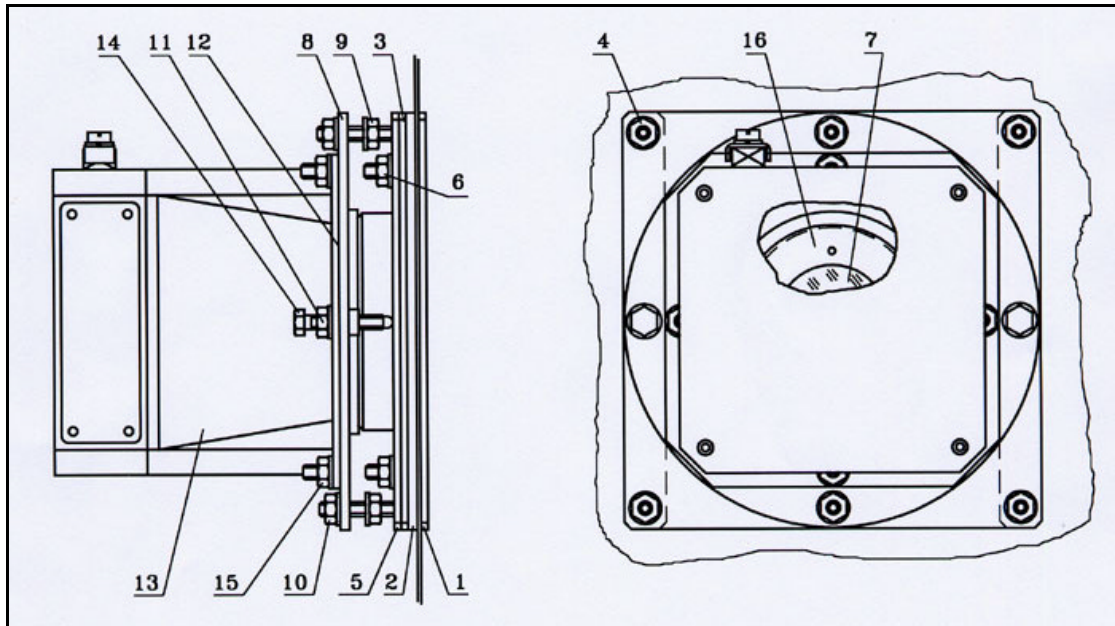

Description			
1	Internal Plate	9	Internal Vertical Alignment Nut and Flat Washer
2	Base Plate Gasket	10	External Alignment Nut and Flat Washer
3	Base Plate	11	Horizontal Alignment Nut and Flat Washer
4	Base Plate Securing Nut and Flat Washer	12	Detector / Light Source Plate
5	Window Plate	13	Detector / Light Source
6	Window Plate Nut and Flat Washer	14	Horizontal Adjustment Locking Screw
7	Window	15	Detector/ Light Source Securing Nut and Flat Washer
8	Alignment Plate	16	Window Nut

Figure 11. Duct Mount Installation - Outline Drawing

### 5.5.5 Duct Mount Alignment (Figures 11,12)

The following instructions are applicable for both the Light Source unit and the Detector unit.

1. Connect the Telescope Plate (Figure 12, item 1) to the Duct Mount Alignment Plate (Figure 11, item 8).  
Insert each one of four Screws (Figure 11, item 15) from the Duct Mount side through the Hole (Figure 12, item 2), and secure it with Nut and Flat Washer (Figure 11, item 15).
2. Locate the Telescope Aim (Figure 12, item 3) to be in vertical to the Installation surface.
3. Look at the Aim view and locate the 'Aim Cross' in the middle of Installation Surface Hole on the opposite side. Rotate the Vertical and Horizontal Nuts (Figure 11, items 10,14) to achieve best result.  
Provide stability of the plate by securing and releasing the opposite nuts or screws gently.
4. Repeat step 3 until best result is achieved.
5. Provide final Screws and Nuts securing (Figure 11, items 9,11).
6. Remove the Alignment set carefully by unscrewing The Nuts and Screws from the Hole (Figure 12, item 2).
7. Perform detector wiring according to section 5.6 Note that in case of Air Duct installation the Detector is mounted at the front side. Therefore, it must be removed from its mounting before any cover opening.
8. Install the Detector/ Light Source on the Alignment Plate (Figure 11, item 8).
9. Secure the Detector/ Light Source with Nuts and Flat Washers (Figure 11, item 15).

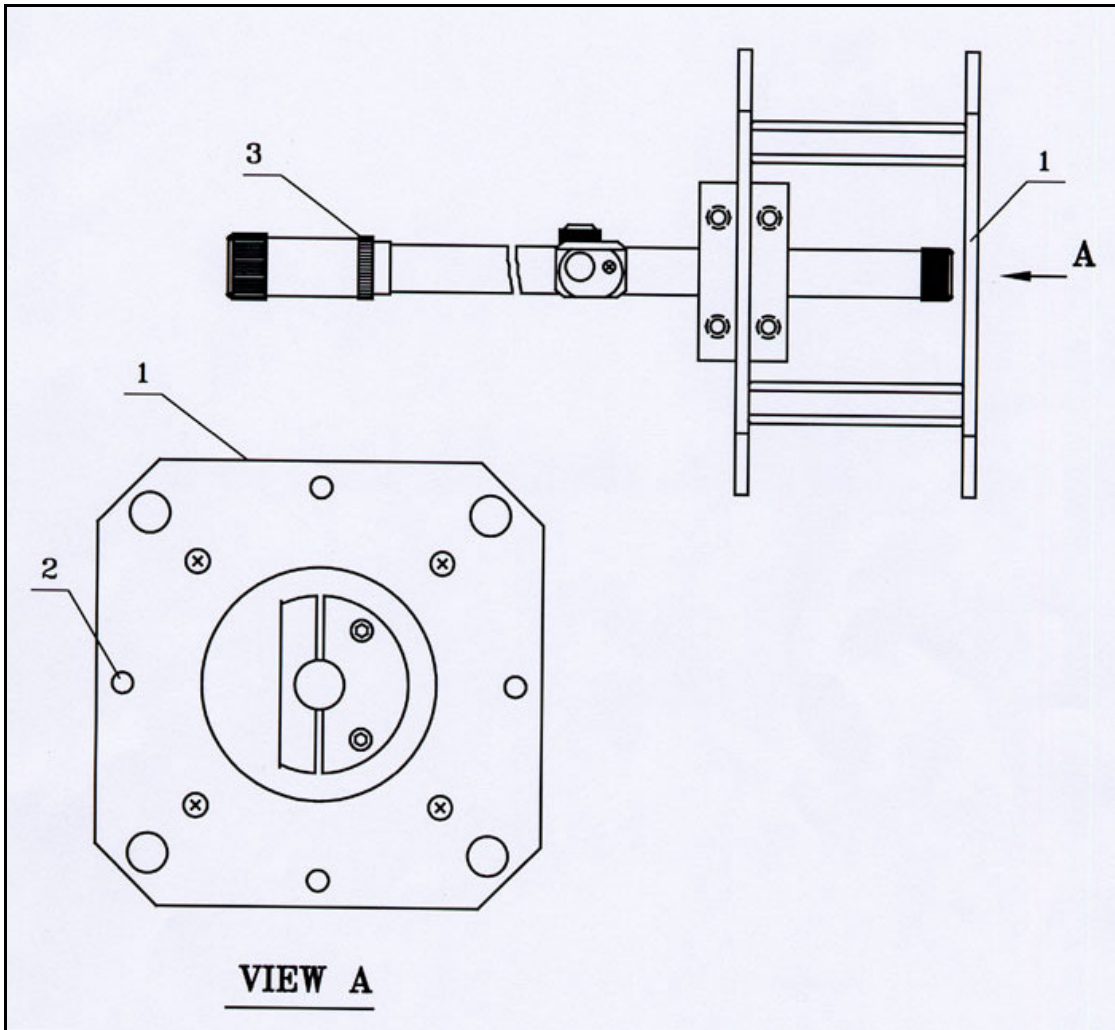

Description	
1	Telescope Plate
2	Detector / Light Source Securing Screw Hole
3	Telescope Aim

Figure 12. Telescope Alignment Set

### **5.6 Detector Wiring (see appendix D if EExde version used)**

This section does not attempt to cover all of the standard practices and codes of installation. It emphasizes specific points providing the basic concept for qualified wiring installation personnel.

#### **Warning!**

Do not separate or close the housing section from the cover while the power is at “on” position.

#### **Caution!**

It is very important that the Cover and Housing sections be exposed to the environment for the least amount of time due to the internal circuitry. Proper planning of the wiring is required in order to reduce the amount of time the Cover and Housing sections are apart.

#### **5.6.1 Conduit/Cable Installation**

1. To avoid water condensation in the detector, it should be installed with the conduits/electrical entries facing downward.
2. When using the Swivel Mount or Duct Mount, use flexible conduits for the last portion connecting to the detector.
3. When pulling the cables through the conduits, ensure that they are not tangled or stressed. Extend the cables about 12 in. (30cm.) beyond the detector location to accommodate wiring after installation.
4. After the conductor cables have been pulled through the conduits, perform a continuity test.

### 5.6.2 Harness Connection (Figure 13)

1. Remove the four Threaded Plugs (13) from detector front.
2. Release the four Socket-Head Screws (14) that secure the detector housing (1) to its back cover (2) using No. 5 Hex Key for M6 screw. Hold the housing during the removal of the screws. Pull the detector housing from its cover. The cover remains attached to the detector swivel mount. The housing slides under the cover and remains attached to it by a securing cable (8). Do not let cover simply drop but rather support it until it hangs.  
The terminal board (12) inside the detector cover is now revealed.
3. Remove the protective plug (6) mounted on the detector conduit inlet. Pull the wires through the detector cover (2) and secure them firmly to the cover using the cable-tie (16) attached to it. Use a 3/4"-14NPT or M25 x 1.5P explosion -proof conduit/electrical entry connection to assemble the conduit/cable to the detector.
4. Connect the wires to the required terminals (12) according to the wiring diagram. See Appendix B.
5. Connect a Grounding Cable to the Ground Terminal (7) outside the detector cover (2). The detector must be well grounded to Earth Ground for proper operation.
6. Verify the wiring. Improper wiring may damage the detector.
7. Check the wires for secure mechanical connection and press them neatly against the Terminal Board (12) to prevent them from interfering while closing the detector's housing.
8. Dress all wires so they will not interfere with the closure of the unit.
9. Seal the conduit inlet and outlet.
10. Align the two connectors guide pins in the Housing section with the correct openings in the housing section.
11. Carefully slide the Housing section onto the floating holes in the Female D Connector.
12. Using the long handled Hex key, tighten the four M6 1.0PX50 screws (14).
13. Insert the four Threaded Plugs (13).



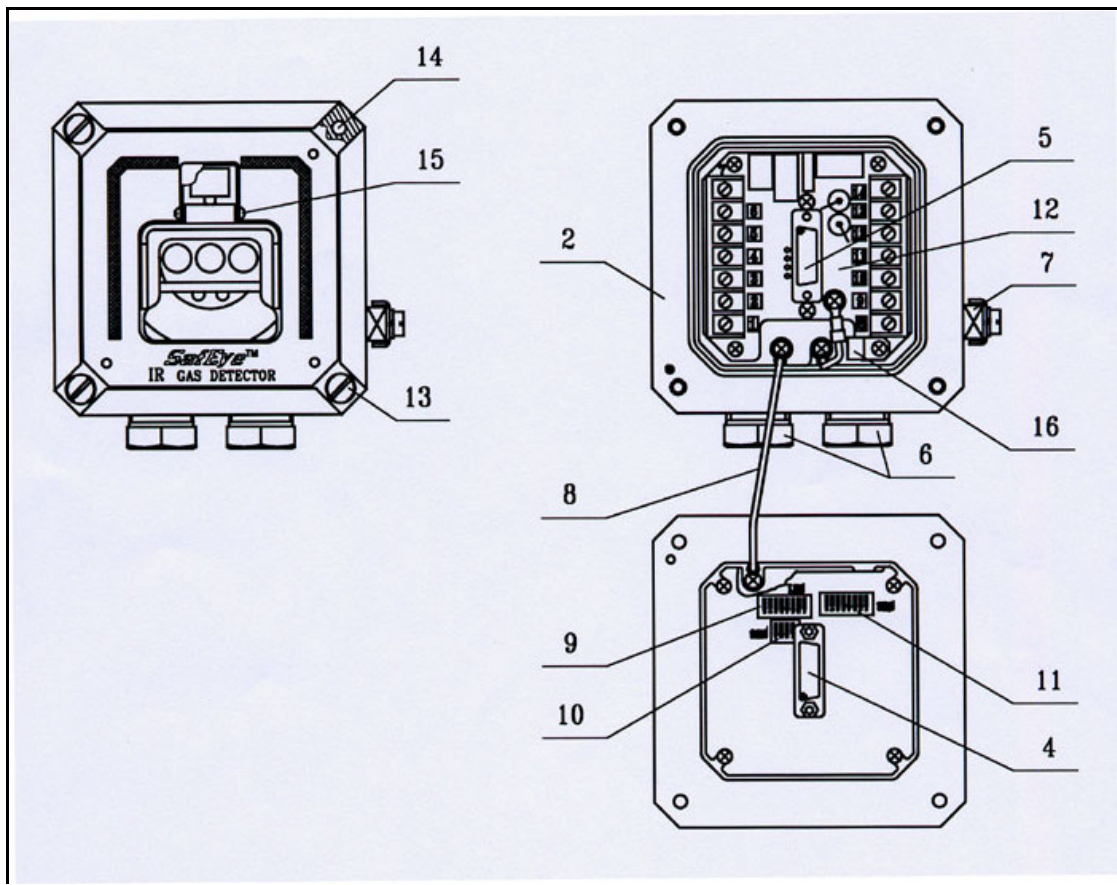

Description			
1	Housing	9	SW1
2	Cover	10	SW3
3	Screw Hole	11	SW2
4	Female D Connector	12	Terminal Board
5	Male D Connector	13	Threaded Plug
6	Conduit Inlet Plug	14	Socket Head Screw (M6x1.0Px50)
7	Ground Terminal Screw	15	Screw Pan Head (No. 4-40UNC-2Ax3/8")
8	Securing Cable	16	Cable Tie

Figure 13. Detector with Cover (removed)

### 5.6.3 Detector Terminal Wiring

The detector contains a terminal board consisting of two terminal blocks.

#### **Power Supply:**

The input power is supplied to terminal 1. The Return is connected to 2.

#### **Note**

Ensure that the detector unit receives a minimum of 18 Volts DC and does not exceed 32 Volts DC.

#### **Fault Relay:**

The Fault Relay is normally open. The SPST relay is at terminal 4 and 5. The contacts are normally energised closed when the detector is in normal operation.

#### **Alarm Relay:**

The Alarm Relay is SPDT Relay. Terminals 6 and 7 are Normally Open and the contacts are closed when the detector is in the Alarm status. Terminals 7 and 8 are Normally Closed and the contacts are open when the detector is in the Alarm status.

#### **Accessory Relay:**

The Accessory output is Normally Open SPST relay. Its contacts are at terminals 9 and 10. It can be defined per user requirements (See Appendix B.)

#### **Note**

To protect the dry contacts from voltage surges when connected to reactive loads (electric motors, sirens, etc.) connect an appropriate varistor over these contacts.

#### **4-20mA Output:**

Terminals 11 and 12 are used for 4-20mA current output as specified in section 3.7.1 (See Appendix B.)

#### **RS-485 Output:**

Terminal 13 and 14 are used for the communication network (See Appendix B.)



## **5.7 Light Source Wiring**

### **5.7.1 Power Supply**

Input power is supplied to terminal 1.  
The return is connected to terminal 2 (see figure 14).

#### **Note**

Ensure that the Light Source unit will receive a minimum of 18 Volts DC and does not exceed 32 Volts DC.

Pre-wiring requirements and wiring requirements are identical to the appropriate requirements for the detector, as described in appendix A.

### **5.7.2 Harness Connection (Figure 13)**

The instructions for this are identical to the detector. Refer to section 5.6.2

### **5.7.3 Terminal Wiring (Table 6)**

The Light Source contains a terminal board. Terminal Wiring Instructions are identical to the Detector Wiring instructions. The Light Source consists of two wires only. The Positive supply power connected to terminal 1, and the common return connected to terminal 2.

Connect the Grounding Cable to the Ground Terminal (Figure 14, item 4) outside the Light Source cover (Figure 14, item 2). The detector must be well grounded to Earth Ground for proper operation.

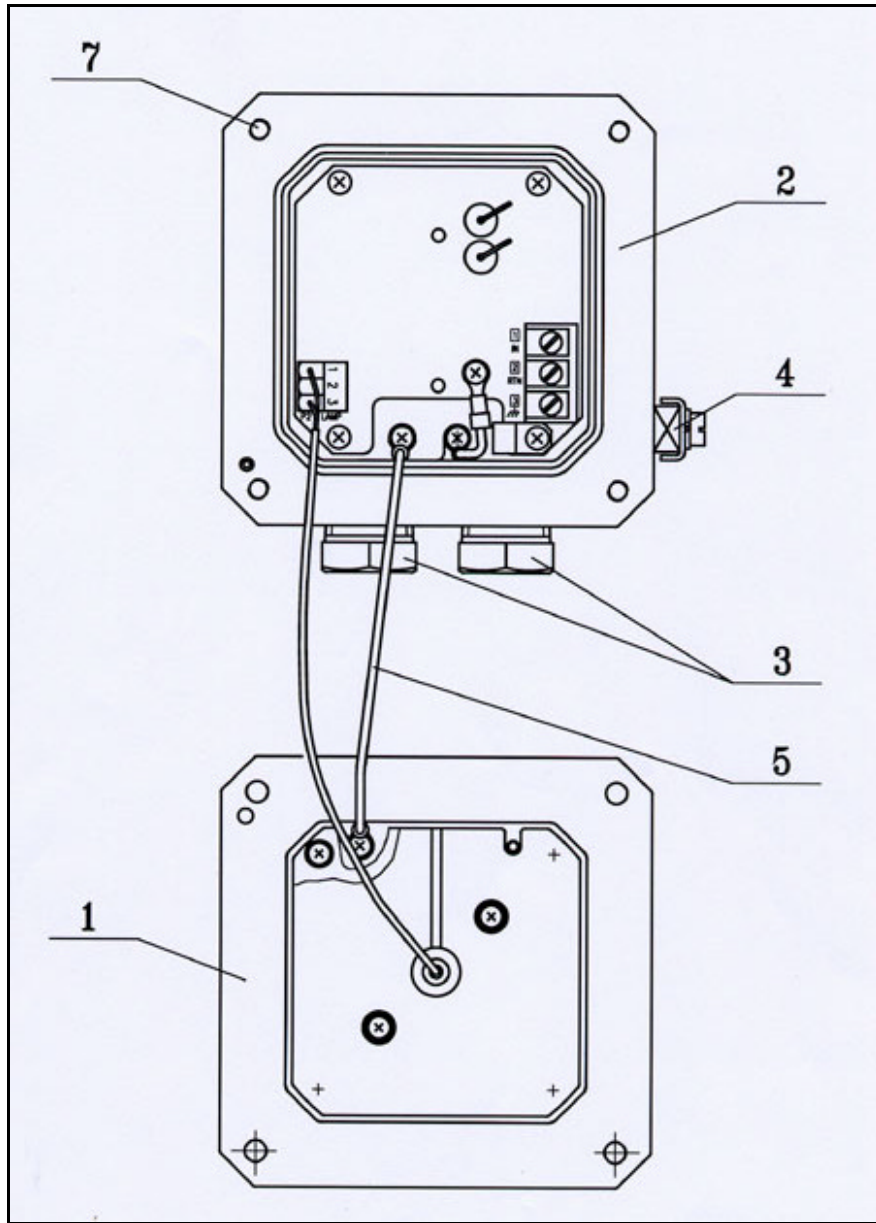

Description			
1	Housing	5	Grounding Wire
2	Cover	6	Securing Cable
3	Conduit /cable Inlet Plugs	7	Screw Hole
4	Ground Terminal Screw	8	DIPswitches

Figure 14. Light Source - Open View

## 6. Operating Instructions

### 6.1 SafEye Operation

Once the system is positioned, it will monitor for possible specified gases, automatically sending signals to a standard control panel or a PC.

This chapter describes the alignment, calibration and operation.

#### **Important!**

Accurate Alignment is essential for proper operation of the SafEye system.

### 6.2 Alignment of Unit (Figures 15 through 16) Using Swivel Mount

(See 6.3 for Alignment using Tilt mounts)

This section applies to open-path installation only. For duct mount applications the alignment is performed according to section 5.5.5. Therefore, skip steps 1 through 10 when duct mount installation is performed.

The Telescope is used for full alignment. Alignment procedure should be performed in two stages: Crude alignment then fine adjustment.

The Telescope includes a Periscope that consists of a prism and an ocular located vertical to the Telescope assembly. This allows the user to observe the opposite unit perpendicular to the alignment when access from the rear of the unit is difficult/impossible. In installations where rear access is possible, the Periscope is not necessary. In this case it can be removed by releasing the Periscope Fastening Screw (item 5 at figure 16).

#### **Important Notes**

- a. Prior to Telescope Installation, verify that the Telescope and Its Sight Mounting are free from any dirt to ensure proper alignment according to factory calibration.
- b. Do not Attempt to change any factory calibration of the Telescope or its mounting. This may prevent optimal alignment.

1. Make sure that the Detector and the Light Source are installed properly. Installation instructions are described in section 5 of this document.
2. Refer to Figure 15. Slightly release four Protective Sight Covers' screws (Figure 15, item 6) from the Detector and the Light Source. Do not remove the screws from the Covers. Remove the Protective Sight Covers (Figure 15, item 7) from the Detector/Light Source Assembly. Store the Cover in a clean place for reinstallation after alignment is completed.
3. Refer to Figure 17. Install the Telescope Assembly (1) on the Telescope Sight Mounting (2) of the Detector according to the drawing. Fasten the Telescope with Fastening Screw (3).

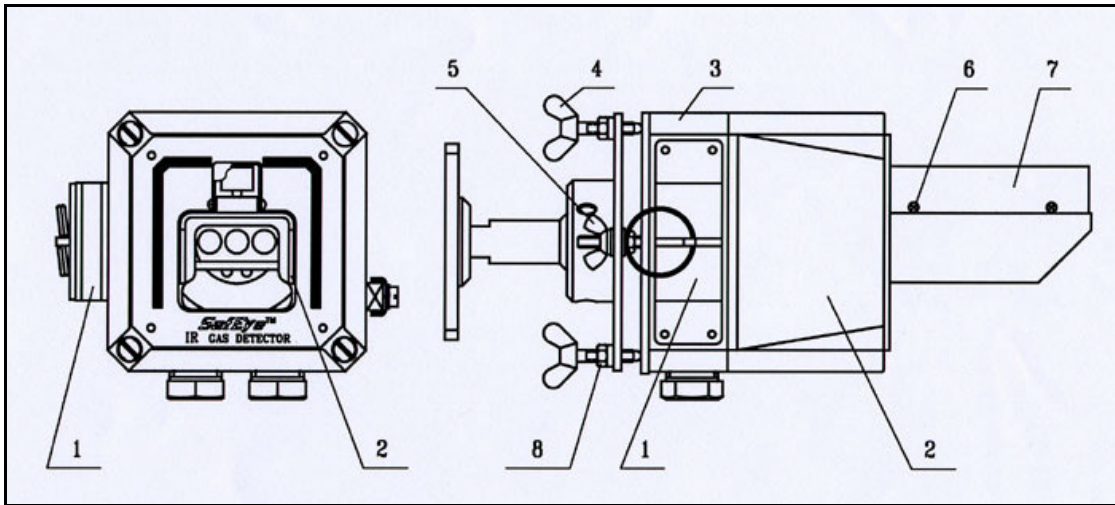

Description			
1	Magnetic Mode Selector	5	Horizontal Adjustment Screw
2	Detector Housing	6	Sight Cover Screw
3	Detector Cover	7	Protective Sight Cover
4	Vertical Adjustment Screw	8	Adjustment Screw Securing Nut

Figure 15. Alignment and Mode Selection

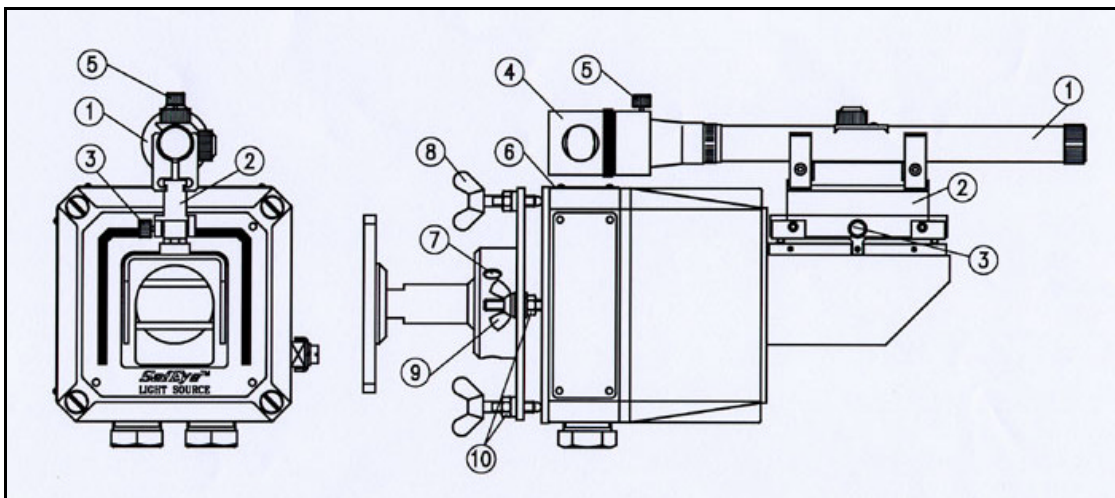

Description			
1	Telescope Assembly	6	Light Source/Detector Housing
2	Sight Mounting	7	Socket Set Screws (3)
3	Telescope Fastening Screw	8	Vertical Adjustment Screw (2)
4	Periscope	9	Horizontal Adjustment Screw (2)
5	Periscope Fastening Screw	10	Adjustment Screw Securing Nut

Figure 16. SafEye Light Source/ Detector Alignment

**4. Detector Crude Alignment:**

Refer to Figure 16 for all the following instructions.

- a. Use 3/16" Allen screwdriver to loosen up the 3 socket set screws (7).
- b. Tilt the Light Source in the general direction of the Detector.
- c. Rotate the Periscope (4) until its ocular is positioned in front of your aiming eye for most convenient observation.
- d. Observe through the Periscope (4) and locate the Detector in the center of view of source unit.
- e. Tighten three socket set screws (7) of the Detector's Swivel Mount.

5. Release the Fastening Screw (3) and remove the Telescope from the Detector.

**6. Light Source Crude Alignment**

Repeat Steps 3 through 4 for the Light Source.

**7. Light Source Fine Adjustment:**

- a. Release the Adjustment Screw Securing Nuts (10) from all Adjustment Screws (8,9) to enable fine alignment.
- b. Watch through the Periscope (4). The cross midpoint inside the Telescope Lens should be aimed to the opposite unit (Light Source) such that it is observed in the Periscope.
- c. Rotate the Vertical Adjustment Screws (8) and the Horizontal Adjustment Screws (9). This should be performed until the cross midpoint is combined with the center of the top of the Light Source Telescope Sight Mounting (Figure 16, item 2).
- d. Carefully secure the four Adjustment Screw Securing Nuts (10). Release the Fastening Screw (3) and remove the Telescope (1) from the unit.

**8. Detector Fine Adjustment**

Repeat Steps 3 and 7 for the Detector.

9. Repeat steps 3,7 and 8 if additional Adjustment is required.

10. Upon alignment completion perform the following:

- a. Reinstall Protective Sight Covers on the Detector and the Light Source by screwing four Sight Cover screws (Figure 16, item 6).
- b. Return the Telescope to its Original case.

11. Power on the system according to section 6.4

12. Perform zero calibration according to section 6.6

13. Perform Signal Intensity Check (SIC) according to section 7.2.2

14. Perform Functional Check (FC) according to section 6.7

### 6.3 Alignment of Unit (Figure 7, 8) Using Tilt Mount

Using the Telescope performs full alignment.

Alignment procedure should be performed in two stages: Crude alignment then fine adjustment.

The Telescope includes a Periscope that consists of a prism and an ocular located vertical to the Telescope assembly. This allows the user to observe the opposite unit perpendicular to the alignment when access from the rear of the unit is impossible. For installations where rear access is possible, the Periscope is not necessary. In this case it can be removed by releasing the Periscope Fastening Screw.

#### Important Notes

- a. Prior to Telescope Installation, verify that the Telescope and its Sight Mounting are free from any dirt to ensure proper alignment according to factory calibration.
- b. Do not attempt to change any factory calibration at the Telescope or its mounting. This may prevent optimal alignment.

Alignment procedure (refer to Figure 8):

1. Make sure that the Detector and the Light Source are installed properly. Installation instructions are described in section 5 of this document.
2. Install the Telescope Assembly (9) on the Telescope Site Mounting of the Source according to the drawing. Fasten the Telescope with Fastening Screw (10).
3. Crude Alignment - Source
  - a. Use 1/4" Allen screwdriver for all alignment screws.
  - b. Loosen screws 5, 6.
  - c. Approximately aim the Source horizontally toward the Detector.
  - d. Tighten screw 5
  - e. Loosen screws 3, 4
  - f. Approximately aim the Source vertically toward the Detector
  - g. Tighten screw 3
4. Repeat 3 for the Detector
5. Fine Alignment- Source
  - a. Aim the source at the Detector within horizontal axis using screws 7. Aim the cross to the upper level of the telescope site of the detector.
  - b. Tighten screw 6.
  - c. Aim within the vertical axis using screw 8.
  - d. Tighten screw 4
  - e. Make sure the telescope cross is pointing at the top of the telescope site of the detector.
4. Repeat 5 for the Detector fine alignment.

## 6.4 Powering on the system

### Important!

Prior to any operation or maintenance follow the Safety Precautions given at section 6.5

1. Make sure that the source and detector are connected to the power.
2. Make sure that the 4-20mA meter is connected to the detector.
3. Power up the system 18-32VDC.
4. After 60 seconds, the left LED lights at green, the current meter will indicate 4mA.

### Note

If it is the first operation after installation, the LED may indicate any status. Zero calibration should be performed after powering the system (see section 6.5).

## 6.5 Safety Precautions

After powering-up, the detector requires minimal attention in order to function properly, but the following should be noted:

1. Follow the instructions in the manual and refer to the drawings and specifications issued by the manufacturer.
2. Do not open the detector housing, while power is supplied.
3. Do not touch internal parts other than the two functional switches.  
Interference with internal circuits may impair detector performance and will invalidate manufacturers warranty.
4. Disconnect external devices, such as automatic extinguishing systems before carrying out any maintenance task.

## 6.6 Zero Calibration

Precise alignment must be performed prior to the calibration procedure. Calibration should be performed in nice weather conditions with insignificant gas concentrations in the surrounding environment or indoors.

### Note

To change modes, place the Magnetic Mode Selector (see Figure 15, item 1) on the detector for 2 seconds and wait for the LED indication.

After mode change allow a time lapse of 5 seconds before changing mode again.

Standby mode is a temporary mode lasting about 20 seconds used to facilitate Zero Calibration mode selection. If the mode selector is not placed during this 20 seconds period, the detector will be switched to Normal mode.

1. Switch from Normal to Alignment mode. See Table 2 for LED status indication.



2. Switch from Alignment to Standby mode. The LEDs will flash alternately with a green color.
3. Switch from Standby to Calibration mode. The LEDs will turn off.
4. Wait up to 60 seconds until it switches to Normal mode (right LED green)  
The detector reading is now set to normal. The 4-20mA output should indicate 4mA.

### 6.7 Functional Check of Unit

The SafEye system has been calibrated at the factory for the User's specific gas or vapor detection requirements. The following procedure validates the functional operation of the system. The Functional Check Filter is a convenient operational check used to confirm that response has not changed from previous readings. The filter is not used for calibration, which is unnecessary, nor does it equate to a particular quantity of gas.

**Caution:**

Automatic activation or any external device that should not be activated during the calibration check should be disconnected.

**Notes:**

1. This functional verification procedure is for a standard 4-20mA output.
2. Prior to starting the functional check, verify that the power to the units is on and that the current of the 4 - 20mA channel is stable. Record the reading.

1. Position the Functional Check filter in front of the SafEye Detector.
2. The functional check filter's window must be centered over the viewing window of the Detector.
3. Wait 20 seconds.
4. Read the 4-20mA current. Determine the difference between the reading taken with and without the Functional Check Filter. This difference is the 4-20mA current variance.
5. Record the 4-20mA current variance in a Maintenance Logbook. If the variance is more than a 30% change when compared to the previous check (see delivery form), repeat the alignment.



## 7. Maintenance Instructions

### 7.1 General Maintenance

The SafEye system requires only simple periodic maintenance to provide satisfactory service and achieve maximum performance. The Detector and Source units can be maintained with the use of common tools and equipment. Record the periodic test results in a Maintenance Logbook with a copy of the delivery form inside.

**Note**

The maintenance can be performed through RS-485, for more details refer to TM792050.

### 7.2 Periodic Maintenance

Recommended cleaning of optical surfaces to be performed periodically.

**Note:**

The frequency of cleaning operations is ultimately dependent upon the existing environmental conditions and the applications used.

- 1 Proper maintenance will allow the SafEye system to retain maximum performance and reliability.
- 2 The optical surfaces of the Source and Detector viewing windows should be kept as clean as possible as it is an active device.
- 3 Alignment procedures must be performed each time that the Source or the Detector unit has been opened or moved for any reason.
- 4 The Signal Verification Check corroborates the current signals from the Light Source compared to that of previous alignments. It is recommended to perform this check every 6-12 months. The signal should be checked according to threshold levels (see. 7.2.2).
- 5 The functional check should be performed every 6 months (see 6.7)
- 6 Zero calibration (see 6.6) must be done every time the Detector or Source is realigned or windows cleaned.

### 7.2.1 Routine Optical Surface Cleaning

The SafEye system, being an optical device, must be kept as clean as possible. The optical surfaces concerned are the Source and Detector viewing windows. To clean the optical window, proceed as follows:

1. Turn off the power to the SafEye detector and source.
2. Where dust or dirt has accumulated on the optical surface, clean the surface with a small, soft-bristle brush.
3. The surfaces must then be washed thoroughly with water and a mild non-abrasive detergent.
4. Thoroughly rinse the glass surface with clean water; ensuring no residue is left behind.
5. Dry the glass with a clean dry soft cloth.
6. Enter in the Maintenance Logbook: Date, name of person and company who performed the maintenance service.
7. Turn on power to the SafEye detector and source.
8. Perform signal verification (section 7.2.2).
9. Perform zero calibration (see section 6.6).
10. Perform functional check (see section 6.7)

### 7.2.2 Signal Verification

The Signal Intensity Check determines if there is a misalignment or if the Light Source signal is wearing over a period of time. Clean the optical surfaces prior to performing this check (see 7.2.1). This procedure should be performed in clear weather.

1. Enter Alignment Mode by placing the mode selector on the side of the detector for 2 seconds.
2. Within the first 20 seconds the Detector indicates 3 different indication levels. See Table 1
3. Wait 20 seconds and count the number of LED flashes with the color, and adjust the value (see Table 18).
4. Record the new results in the maintenance log book.
5. Determine the absolute variance compared with the previous alignment reading in the maintenance logbook.
6. If the variance is more than 30%, perform alignment (see section 6) and zero calibration (see section 6.6). Call a technician for service if the SIC is less than 66 with both LED's flash in red color.

**Table 18. LED Signal Adjustment**

Color (left-right)	Number to be added
Red-Red	0
Orange-Orange	62
Green-Orange	124
Green-Green	186

**Example:**

At a hypothetical installation the LEDs are Green-Orange with 3 green flashes (left LED) and 6 orange flashes (right LED).

The number is  $36 + 124 = 160$

The next periodic maintenance reading has Orange-Orange LEDs with 8 orange blinks (left LED) and 8 orange flashes (right LED).

The number is  $88 + 62 = 150$

The variance is  $160 - 150 = 10$  Units

The percentage of variance will be  $(10/160) * 100 = 6.25\%$  less than previous alignment.

**7.2.3 Function Check of Unit**

The SafEye system has been calibrated at the factory per the user's specific gas or vapor detection requirements. This procedure validates the functional operation. The functional check must be done periodically. Refer to 6.7 for instructions.

**Caution:**

Automatic activation or any external device that should not be activated during the calibration check should be disconnected.

**7.2.4 Maintenance Records**

Record every maintenance operation performed on the Source and/or Detector in a Maintenance Log-book. The logs should include but not be restricted to the following:

- The information identifying the measurement units.
- The date of installation and contractor.
- Entries for every maintenance operation performed to include at least the description of the operation, date and personnel ID.
- Signal intensity records with SIC results.
- Calibration check (CC) results.

If the unit(s) is (are) sent to the authorized Supplier, a copy of the Maintenance Records must accompany the unit concerned.

## 8. Troubleshooting

Problem	Cause	Solution
LEDs are off and Fault is indicated at 0 mA level	Power is not supplied to the Detector	Supply power to the Detector
Both LEDs are on at yellow and fault is indicated at 0mA level	Fault 2	Bring the detector unit for service.
Both LEDs are flashing at yellow and fault is indicated at 0mA level	Low voltage is supplied to the detector	Check the voltage level supplied to the detector
One LED is on at yellow and 4-20mA indication level is 2mA	Dirt has accumulated on the detector's window or on the Light Source's window	Clean the optical windows (See Section 7.2.1).
	One unit at least has been moved or tilted	Perform Realignment (See section 6)
	Power is not supplied to the Light Source	Supply power to the Light Source
	The optical open path beam is blocked	Remove the obstruction
	One unit at least has been moved or tilted	Perform Realignment (See section 6)
	Electrical problem at the Light Source	Perform SIC in order to measure signal intensity  Bring the Light Source to a technician for service if it is not flashing

## Appendix A - Wire Selection Tables

### General Instructions For Electrical Wiring

1. mA output or relay wiring - refer to Table 20 to determine the required wire gauge for general wiring Calculate the permitted voltage fall with respect to loads current, wire gauge and length of wires.
2. Power supply wires - refer to Table 21 to select wire gauge. DO NOT connect any circuit or load to Detectors' supply inputs.

**Table 19. Maximum DC resistance at 68°F for copper wire**

AWG #	mm <sup>2</sup>	Ohm per 100 ft.	Ohm/100 meter
26	0.12 - 0.15	4.32	14.15
24	0.16 - 0.24	3.42	11.22
22	0.30 - 0.38	1.71	5.60
20	0.51 - 0.61	1.07	3.50
18	0.81 - 0.96	0.67	2.20
16	1.22 - 1.43	0.43	1.40
14	1.94 - 2.28	0.27	0.88
12	3.09 - 3.40	0.17	0.55
10	4.56 - 6.64	0.11	0.35

1. Select "Number of Detectors" connected in one circuit.
2. Select "wiring length" per your installation requirements.
3. Refer to "power supply range" for voltage extreme applied.

**Table 20. Wiring length in feet (meter)**

No. of Detectors	Recommended Wire Diameter					Power Supply Range (VDC)
24	18	16	14	-	-	22-32
20	18	16	14	-	-	22-32
16	20	18	16	14	-	22-32
12	20	18	16	14	-	20-32
8	20	18	16	14	-	20-32
4 and less	20	18	16	16	14	20-32
Feet (Meters)	164 (50)	328 (100)	492 (150)	656 (200)	820 (250)	
	Max. Length from Power Supply to Last Detector					



## Appendix B: Wiring Option configurations

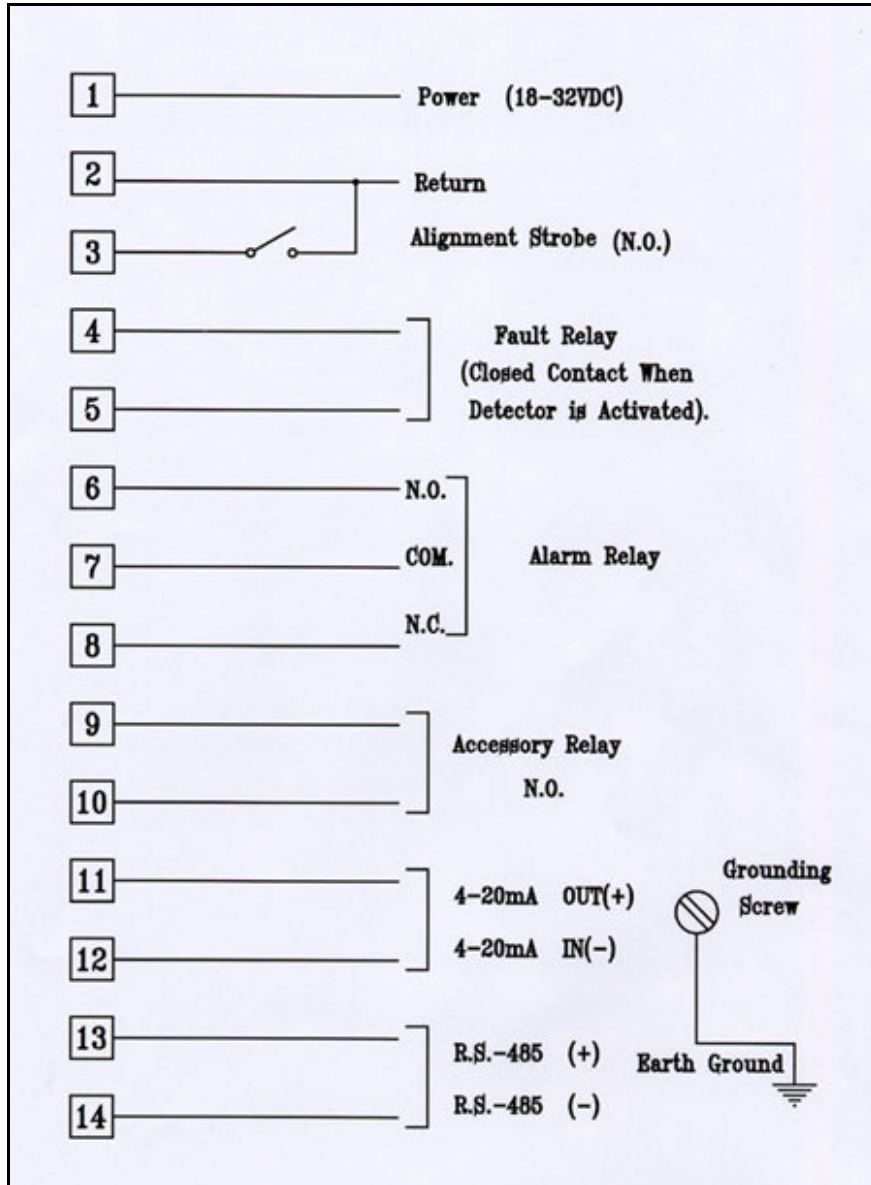

Figure 17. Detector's Wiring Diagram



Figure 18. 4-20mA Source Output

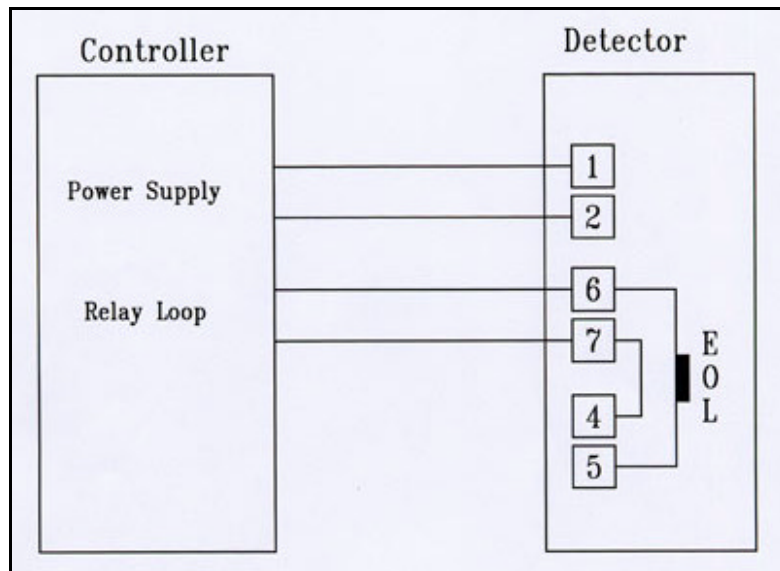

Figure 19. Typical 4 Wire Controller



## RS-485 Communication Network

By using the RS-485 network capability of the SafEye Detector and additional software, it is possible to connect up to 32 Detectors in an addressable system with four (4) wires only (2 for power and 2 for communication). Using repeaters, the number of Detectors can be much larger (32 Detectors for each repeater) up to 64 on the same four (4) wires. When using the RS-485 network, it is possible to read each Detector status (FAULT, WARNING, and ALARM).

For more details, consult the factory.

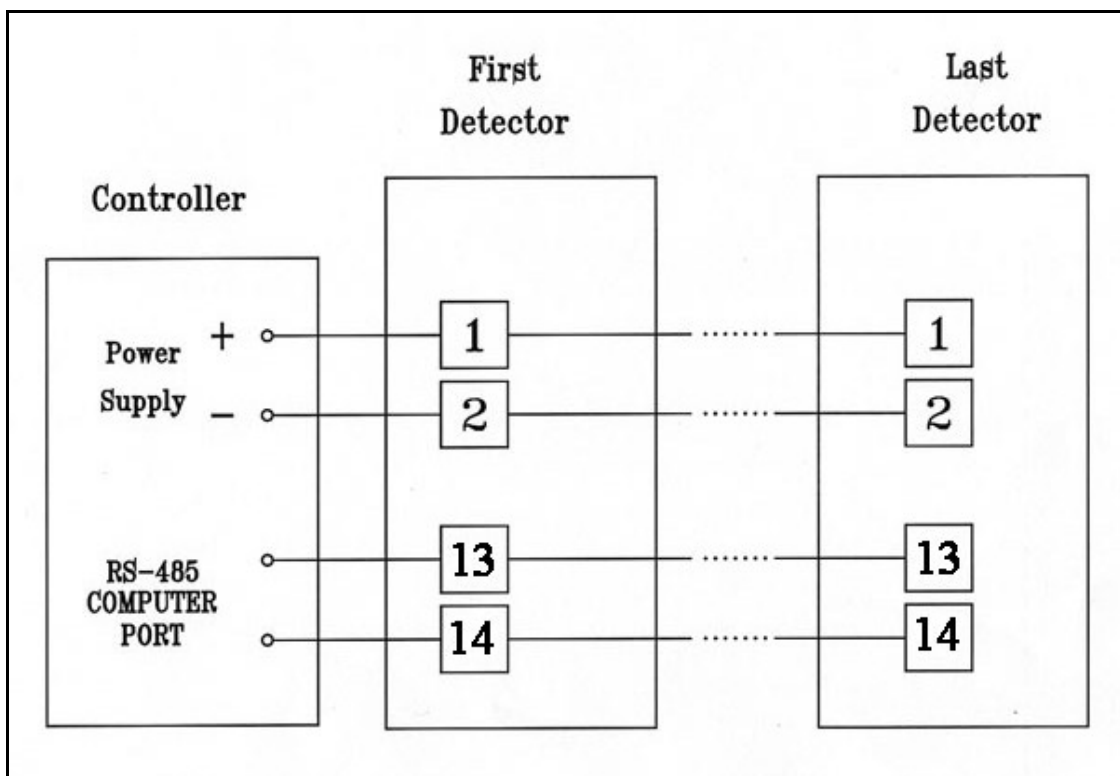

Figure 20. RS-485 Networking



## Appendix C: Outline Drawing

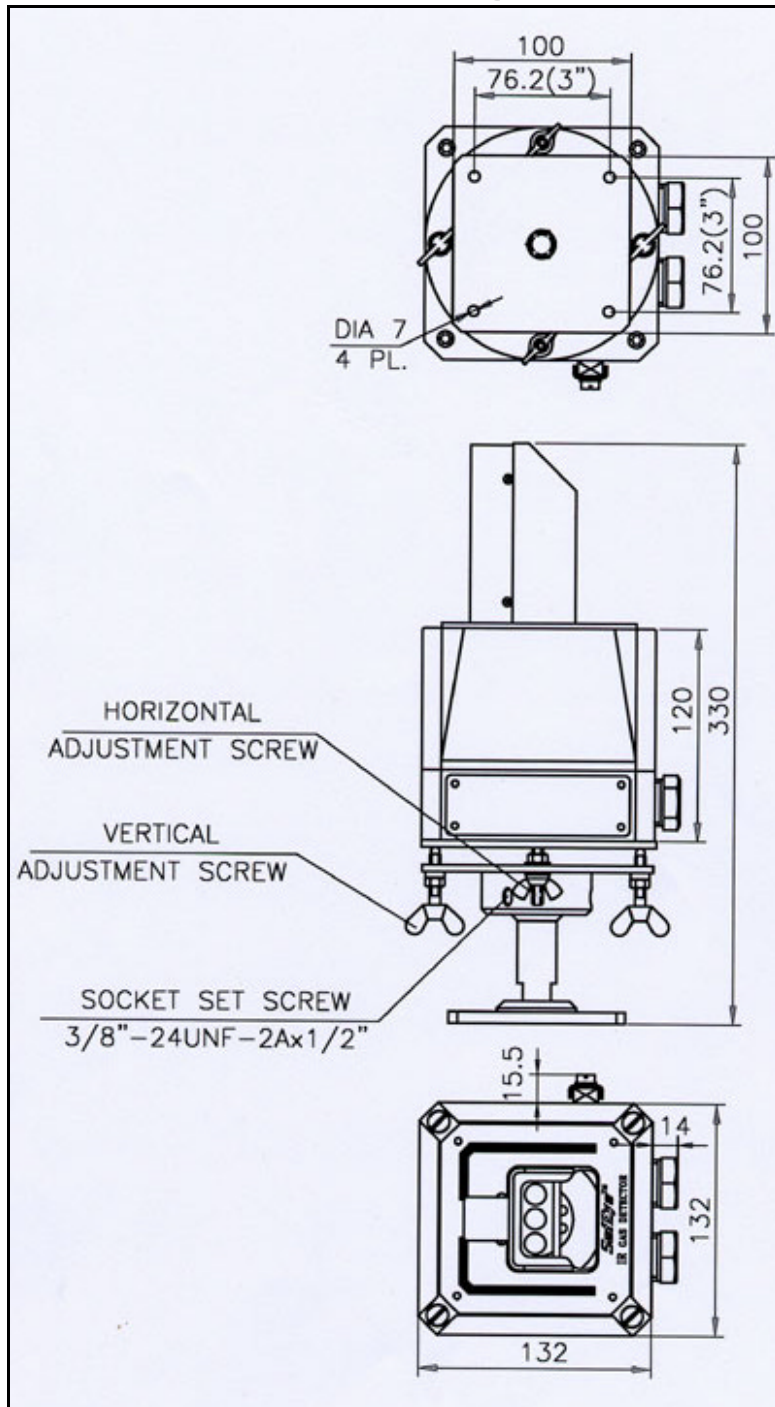

Figure 21. Detector Outline Drawing With Swivel Mount

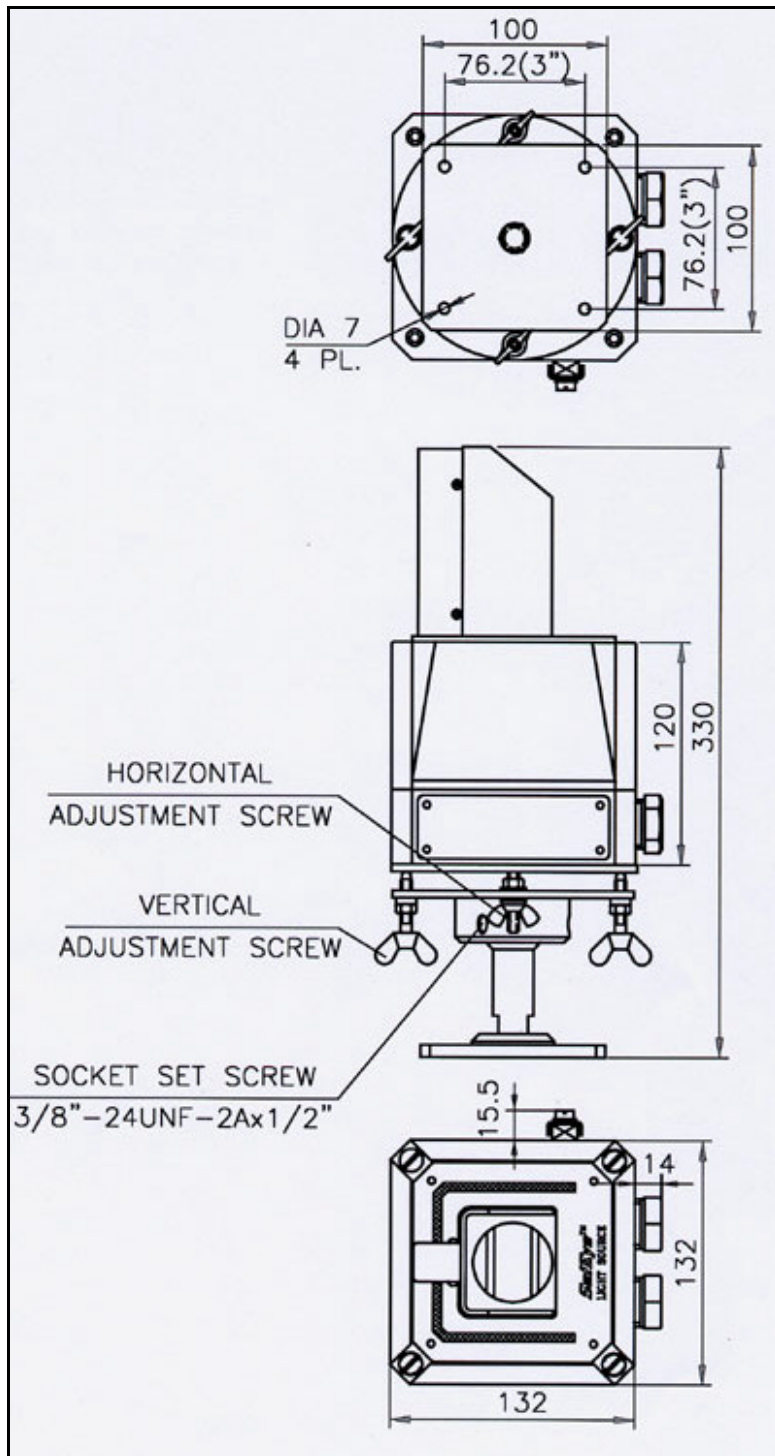

Figure 22. Source Outline Drawing (Reflector Type) With Swivel Mount

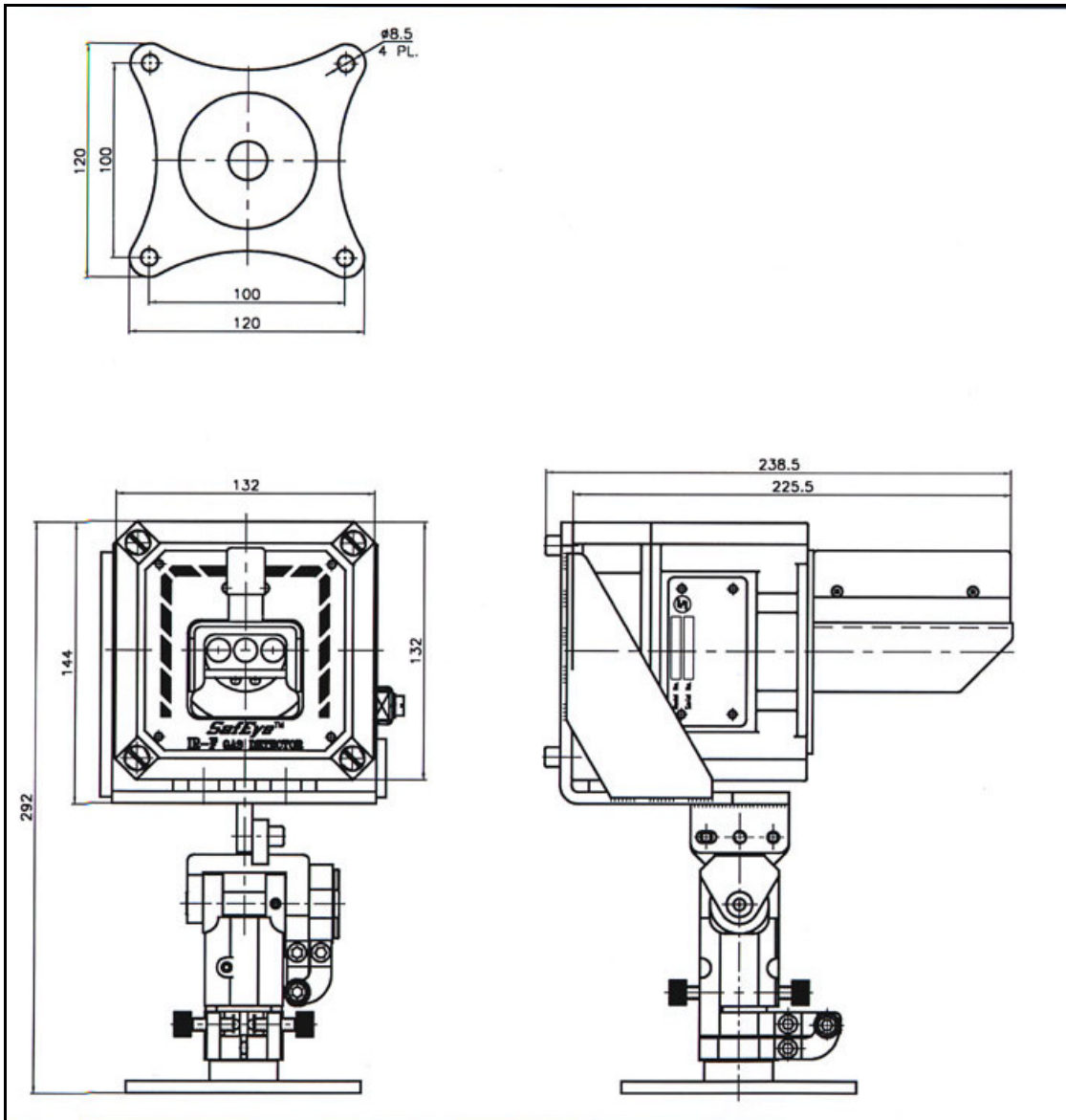

Figure 23. Detector and Tilt Mount Outline Drawing

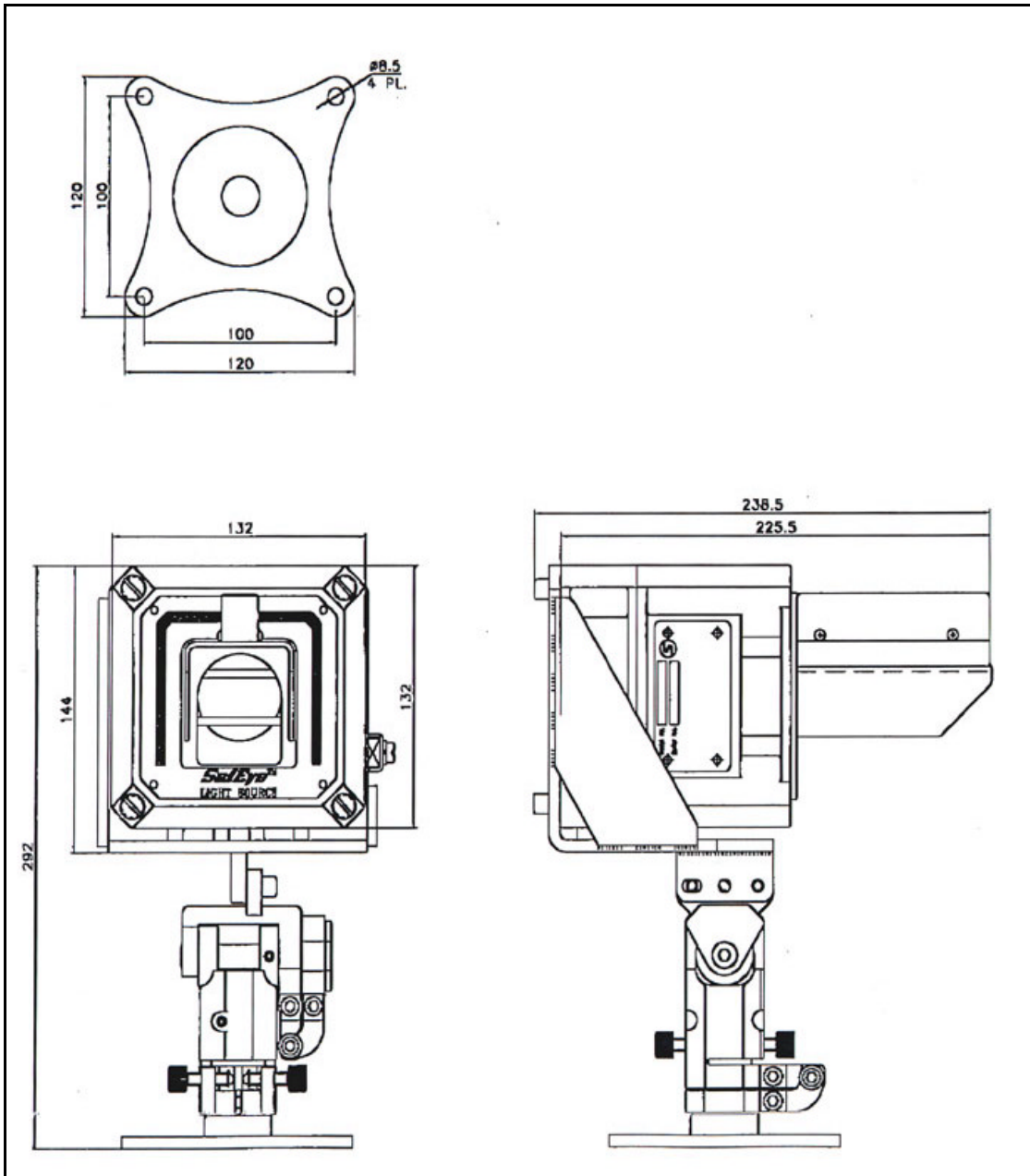

Figure 24. Source and Tilt Mount Outline Drawing

## Appendix D - Mounting the “EExde approved” version

The EExde approved version provides an additional EExe terminal box attached below the EExd detector and therefore allows easier access in hazardous areas (see fig. 25). The unit is prewired to the terminals in the additional EExe terminal section ready for field wiring connections

### 1. Detector/Source Mounting

The detector should be mounted by one of the following options:

- a. Swivel mount refers to paragraph 5.4.1.
- b. Tilt mount refers to paragraph 5.4.3.
- c. Duct mount refers to paragraph 5.5.

#### 1.1 Installation

All the installation instructions are the same as defined in Paragraph 5.4.1, 5.4.3 and 5.5.

- a. On swivel mount option there are two options of detector/source install on the swivel mount.  
You can use the thread on the de cover marked either Triangle Symbol or a Square Symbol (Figure 25).
- b. On tilt mount option you must use the Triangle Symbol.
- c. On duct mount the detector is installed from the front of the detector.

### 2. WIRING (REFER TO FIG. 25.)

- 1 Disconnect power.
- 2 Release the four (4) slotted-head screws (item 3) that secure the chamber cover (Item 2). The chamber is now revealed.
- 3 Remove the protective plug mounted on the detector conduit inlet, pull the wires through the detector chamber (Item 7). Use M25x1.5 explosion-proof conduit connection to assemble the conduit to the detector.
- 4 Connect the wires to the required terminals (Item 4) according to the wiring diagram. See paragraph 2.1 and figures no. 26 and no. 27.
- 5 Connect the grounding wire to the ground screw outside the detector cover (Item 5).

**The detector must be well grounded to *Earth Ground* for proper operation.**

- 6 Verify the wiring. Improper wiring may damage the detector.
- 7 Check the wires for secure mechanical connection and press them neatly against the terminal to prevent them from interfering while closing the cover (Item 2).
- 8 Place and secure the cover chamber (Item 2) using four (4) slotted-head screws (Item 3).

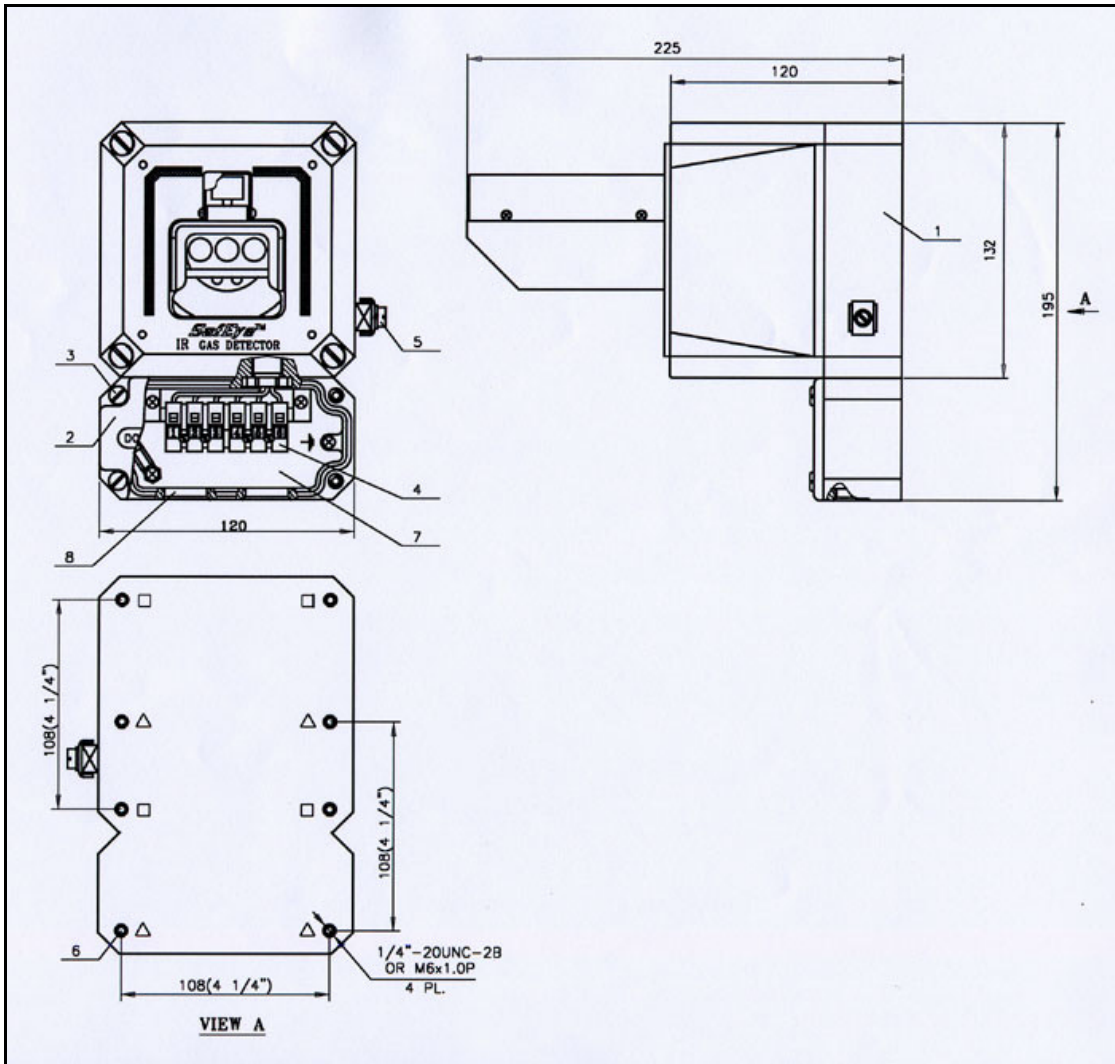

Description	
1. Modified Back Cover	5. Ground Terminal
2. EExe Chamber Cover	6. Mounting Thread
3. Slotted Screw	7. EExe Chamber
4. Terminal Block	8. Conduit Inlet

Figure 25: Flame Detector Assembly - Wiring Diagram



### 2.1 Terminal Wiring

Each detector and source unit has a separate EExe terminal box directly attached/assembled to it and prewired to the terminal strip in the EExe box (Item 4). There are two possible wiring options – please follow the wiring scheme below which is appropriate to that ordered:

The terminal block is labeled 1 to 6 (See Fig. No.25)

The following describes the function of each electrical terminal of the detector:

RS-485 & 4-20mA Version Option A (See Fig. No. 26)	Alarm & Fault Relays Version Option B (See Fig. No. 27)
<p><b>Power Supply</b> (Terminal Numbers 1, 2): Input power - Terminal No. 1. RETURN - Terminal No. 2.</p>	<p><b>Power Supply</b> (Terminal Numbers 1, 2): Input power - Terminal No. 1. RETURN - Terminal No. 2.</p>
<p><b>RS-485</b> as specified in appendix C. (Terminal Numbers 3, 4): Terminal No. 3 - positive (+) lead. Terminal No. 4 - negative (-) lead.</p>	<p><b>Alarm Relay</b> (Terminal Numbers 3, 4): The Alarm output is a NO. SPST contact at Terminal Numbers 3 and 4. The contacts are closed at Alarm Mode.</p>
<p><b>4-20mA Output</b> (Terminal Numbers 5, 6): as specified in paragraph 5.e Terminal No. 5 - output Terminal. Terminal No. 6 - input Terminal. (see appendix B for more details)</p>	<p><b>Fault Relay</b> (Terminal Numbers 5, 6): The Fault output is N.C. SPST contact at Terminal Numbers 5 and 6. The contacts are open at Fault condition.</p>
<p><i>Figure 26: OPTION A Detector Assembly - Wiring Diagram</i></p>	<p><i>Figure 27: OPTION B Detector Assembly - Wiring Diagram</i></p>

Distributed By



GasTech Australia Pty Ltd  
24 Baretta Rd  
Wangara Western Australia 6065  
Tel 1800 999 902  
Fax 1800 999 903  
<http://www.gastech.com.au>